





# POLARSTEM<sup>◇</sup>

## Contents

Introduction .....	1
Precautions regarding Surgical Technique.....	2
Case Studies .....	3
Preoperative Planning .....	4
Surgical Technique .....	5
Postoperative Treatment .....	12
Sterilization.....	12
References.....	12
Implants.....	13
Dimensions .....	15
Instrument Set.....	17

## Nota Bene

The surgical technique described in this brochure is the procedure suggested by the authors for uncomplicated surgery. The surgeon must, however, decide which procedure is the most suitable and effective for each individual patient.

e-IFU homepage: [ifu.smith-nephew.com](http://ifu.smith-nephew.com)

The following technique is for informational and educational purposes only. It is not intended to serve as medical advice. It is the responsibility of treating physicians to determine and utilize the appropriate products and techniques according to their own clinical judgment for each of their patients. For more information on the product, including its indications for use, contraindications, and product safety information, please refer to the product's label and the Instructions for Use.

---

## Introduction

The POLARSTEM<sup>®</sup> has been clinically used since 2002 with excellent clinical results for over 10 years and is based on a philosophy that has yielded excellent clinical results in the last +25 years.<sup>1,2</sup>

The simple surgical technique helps to achieve reproducible results and allows implantation using both conventional and minimally invasive techniques.<sup>3-6</sup>

The POLARSTEM can be used for all standard femoral morphologies. The range of stems allows the implant to be matched to all bone sizes, thereby reproducing the natural hip architecture.<sup>6</sup>

The cementless POLARSTEM range includes 13 standard femoral stems with a CCD angle of 135°, 11 lateral femoral stems with a CCD angle of 126° and 8 valgus femoral stems with a CCD angle of 145°. In the case of coxa vara, the CCD angle is smaller than normal. Implanting a stem prosthesis with a CCD angle of 135° or more can result in a medialization and/or lengthening of the leg. By implanting a lateral stem, the lever arms can be reconstructed in such a way that the strength of the pelvic-trochanter muscles is restored. At the same time, an optimal soft tissue tension is achieved. This is intended to minimize the risk of an inadequate gait and the risk of luxation, if required by the preoperative planning.

Standard and lateral offset stems are also offered in a collared version. All cementless implants are coated with an open-pored titanium plasma/HA coating. The cemented POLARSTEM range includes 9 standard femoral stems and 8 lateral femoral stems.

---

## Precautions regarding Surgical Technique

### Reliable fit of femoral ball heads on stem tapers

The taper connection can only be reliably and firmly seated if the surface of the ball head cone and the surface and structure of the hip stem taper are completely intact. The disposable plastic cap protecting the stem taper from damage shall not be removed until the trial ball is attached. To ensure that the ball head performs as required, it is essential to take great care when attaching it to the stem taper: Clean and dry the neck taper with a clean, sterile cloth. Place the prosthetic femoral head on the neck taper and firmly impact with the femoral ball head impactor and a mallet several times. Never reuse a femoral ball head that has been impacted onto a stem cone and then removed.

### Restrictions on head/insert combinations

- BIOLOX® forte/delta ceramic inserts must only be combined with BIOLOX® forte/delta ceramic ball heads

### Restrictions on head/taper combinations

- Material: Stainless steel (FeCrNiMoNbN) heads and stainless steel stems should only be used together. Neither should be used with other metal components. This limitation excludes OXINIUM® and BIOLOX OPTION heads, which have been tested and approved in combination with cemented POLARSTEM® made of stainless steel.
- Sizes: all ball head sizes of Smith&Nephew Orthopaedics AG can safely be used with all hip stems of Smith&Nephew Orthopaedics AG. For combinations with components of other manufactures (e.g. Smith & Nephew Inc.), the surgeon must verify if the combination is allowed as listed in the compatibility matrix (lit. no. 04758) available on [ifu.smith-nephew.com](http://ifu.smith-nephew.com). Ball heads should only be combined with hip stems of identical taper dimensions.

### Femoral ball head revisions

For the revision of a femoral ball head, apply the following:

- The corresponding insert has to be revised as well.
- Replacement only by a metal ball head or a special ceramic revision femoral ball head featuring a modular titanium-sleeve (BIOLOX® OPTION). Do not assemble a standard ceramic head on a used taper; the ceramic head may fracture from irregularities on the femoral component taper.
- In the case of a revision involving a fractured ceramic component, femoral ball head and insert have to be revised. Remove all loose identifiable fragments and thoroughly irrigate and lavage the operative site. Be careful in performing this step: There is a risk of injury from sharp edges of ceramic fragments. A special ceramic revision femoral ball head coupled with a modular titanium-sleeve should be used if the femoral taper is intact. Metal or OXINIUM femoral ball heads with a polyethylene insert shall not be used for revising fractured ceramic components. In case the taper is damaged or no appropriate ceramic revision femoral ball head is available, the femoral stem must be revised to provide a suitable femoral taper to attach a new ceramic ball head.
- If the stem remains in situ in hip revision surgery, contact between high-frequency instruments and the metal implant shall be avoided. If there is contact of high-frequency electro-cauterization instrument with metal implants, flashover can occur. This can lead to thermal microstructural changes in the material and as a consequence may reduce the fatigue strength of the implant.

## Case Studies

Preoperative

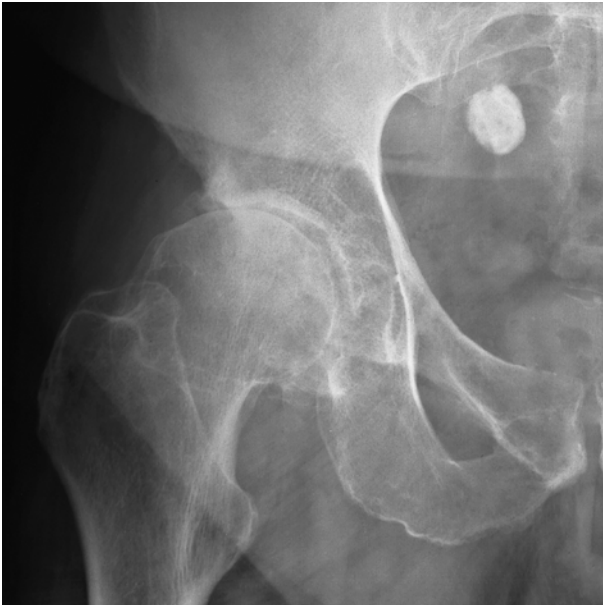

Female, 72 years of age, cox arthritis

Postoperative



Combination of POLARCUP® and cementless POLARSTEM®

Preoperative



Male, 70 years of age, cox arthritis

Postoperative



Combination of POLARCUP and cementless POLARSTEM

# Preoperative Planning

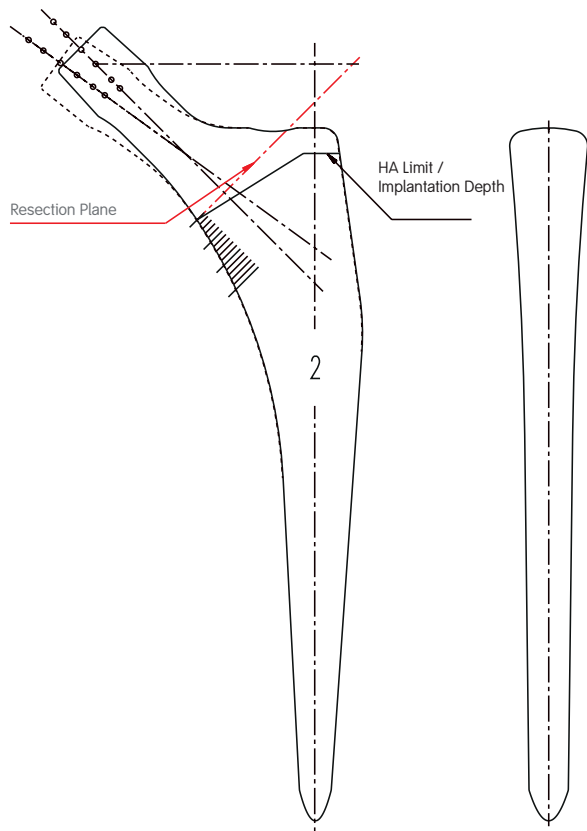

Preoperative planning is essential for determining the size of the femoral and acetabular components.

## Preoperative planning requires:

- X-rays
- Templates for the acetabular component and the stem or
- Digital templates for the acetabular component and the stem

Templating should define the reaming required for the restoration of the cup's center of rotation, while the height and angle of the neck resection determine the optimal length and offset.

Standardized AP and lateral X-rays are essential to ensure accurate planning. The femur must be positioned in neutral rotation to produce orientation that matches the templates.

An adequate length of the femoral diaphysis should be included on the X-rays. The correct stem size is determined by laying the stem template over the X-ray and selecting the optimum fit of the stem by aiming for medial and lateral contact to the inner cortex. The center of rotation of the femoral head is matched by selecting the appropriate neck length. The level of resection is shown by the template.

The following acetate X-ray templates are available for POLARSTEM®:

Item No.	Name
71381794	POLARSTEM X-ray templates Standard / Lateral 1.15
71381795	POLARSTEM X-ray templates Standard / Lateral 1.20
71381796	POLARSTEM X-ray templates Valgus 1.15
71381797	POLARSTEM X-ray templates Valgus 1.20
71381798	POLARSTEM X-ray templates Collar Standard / Lateral 1.15
71381799	POLARSTEM X-ray templates Collar Standard / Lateral 1.20

## Warnings and precautions

HA-coated implants must not be implanted with cement.

Please contact your local Smith & Nephew sales representative or distributor to order X-ray templates or in case of any other product related question.

# Surgical Technique

The same instruments can be used for implanting cementless and cemented stems.

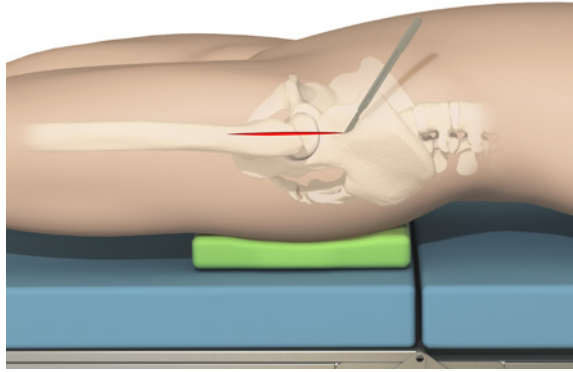

## Position of the patient and approach

For the purpose of this description a lateral approach is chosen. Surgery is performed with the patient in an extended supine lateral position.

Whether an anterolateral, lateral, posterolateral or posterior approach is used is at the surgeon's discretion. The skin incision and muscle detachment depend on the selected approach. All implants and instruments also suit a minimally invasive approach.

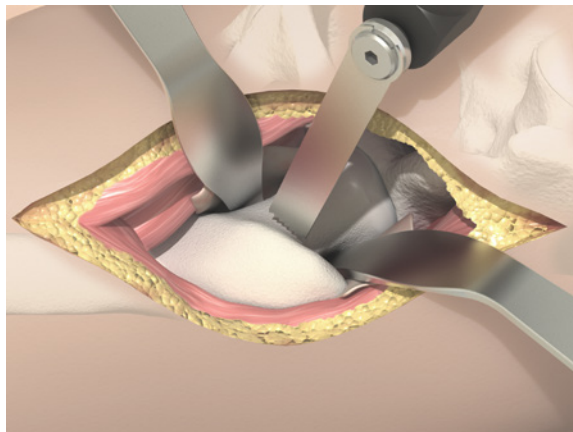

## Removing the femoral head

Laterally, the osteotomy commences at the trochanteric fossa (perpendicular to the neck axis), while medially it ends approximately a finger breadth above the lesser trochanter. The height of neck resection may be modified in the presence of abnormal anatomy as determined by preoperative templating and intraoperative measurements. The osteotomy can be performed before or after dislocation of the femoral head.

The acetabulum is replaced in a routine manner, conventionally or with a minimally invasive approach.

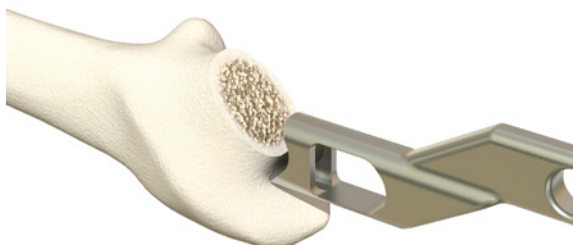

## Preparation of the femur

The opening of the medullary cavity is performed with the offset hollow chisel, allowing the correct anteversion required for the implant – starting as close as possible to the greater trochanter base to allow good varus/valgus positioning.



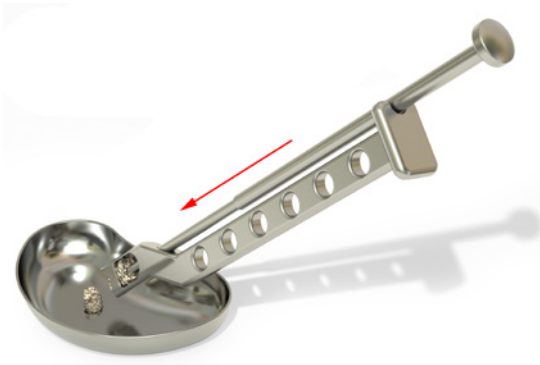

The instrument is supplied with a thin rod, allowing easy removal of extracted bone.

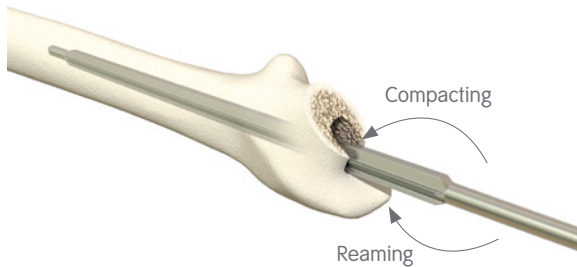

The femoral reamer is then introduced in the medullary canal. The canal axis is located using the endosteum.

**Note**

After introduction, we recommend turning the reamer counter clockwise to compact the cancellous bone. To advance the reamer deeper into the bone it then can be turned clockwise to penetrate further. Remove any (excess) bone material.

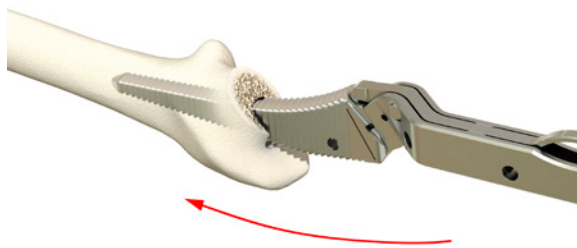

Starting with the smallest size 01 of the detachable rasp, continue using the next size rasp each time, until the appropriate rasp is fully seated

**Note**

POLARSTEM<sup>®</sup> rasps have bone cutting teeth medial and lateral to provide stable self-locking of the implant. Anterior and posterior the rasp design is different to allow compaction of cancellous bone.

We recommend that the first rasp 01 is pushed laterally towards the greater trochanter to avoid a varus position of the stem.

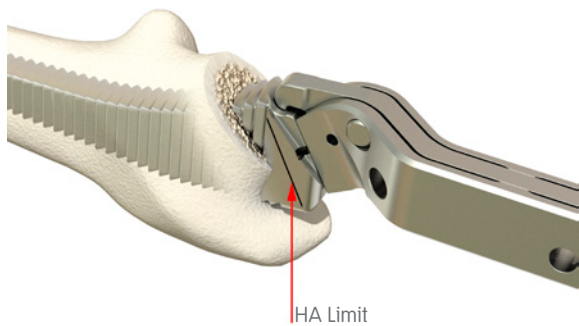

The level of the HA coating is indicated on the rasp.

**Note**

We recommend that the HA-coated part of the stem is completely covered by the femur.



Different offset versions of the rasp adapter are available to accommodate the selected surgical approach and/or patient size. Please refer to the instrument sets as of page 20.



All adapters can be used with the IMT power tool WOODPECKER or with the modular knock plate (75000642/21000378). At this stage anteversion can be checked using the bolt (75001747/1060909) inserted through the knock plate.

The WOODPECKER is a pneumatically powered device for hip broaching from IMT Integral Medizintechnik AG, Switzerland

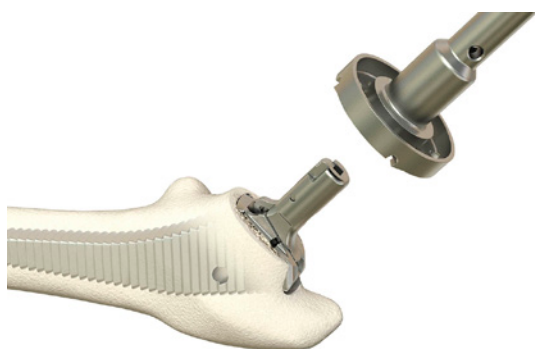

**Optional calcar reaming (for collared stems)**

Once the appropriate detachable rasp size is in place, the adapter is removed and the calcar reamer guide (75102205) is positioned on the rasp.

The calcar planer small (75103199) and/or calcar planer large (75103200) is placed over the reamer guide and the femoral neck is machined until the reamer reached the physical stop - fully seated on the inner reamer guide.

Whenever possible, the small calcar planer is preferred to protect surrounding soft tissues. Therefore, always check first, if the small calcar planer would be large enough by placing the small size over the reamer guide attached to the final rasp. Only use the large calcar planer, if the small one cannot fully cover the medial calcar section.

### Trial reposition

Once the appropriate detachable rasp size is in place, the adapter is removed and the trial neck (Standard, Lateral or Valgus) is positioned on the rasp.

#### Note

Rasp sizes 01 and 0 require separate Standard trial necks. Rasp sizes 1–11 correspond with the same trial neck. For collared implants, specific trial necks can be used, which show the position of the collar at the final implant.

### Important

There is a little gap of about 1mm between planer calcar bone and bottom side of the collar. This is by purpose to avoid that the implant rests on the collar before finally seated and self-locked in the bone.

Optionally, the pin 100 mm (75004664/21000340) can be introduced through the trial neck to check the level of the stem in relation to the greater trochanter. The level of the pin corresponds with the center of the trial / ball head M/+4.

Once the pin has been removed, a trial head is placed on the trial neck. Trial reduction is then performed to assess height, stability and absence of neck-shell impingement before inserting the final femoral component.

Remove the trial head, trial neck and detachable rasp.

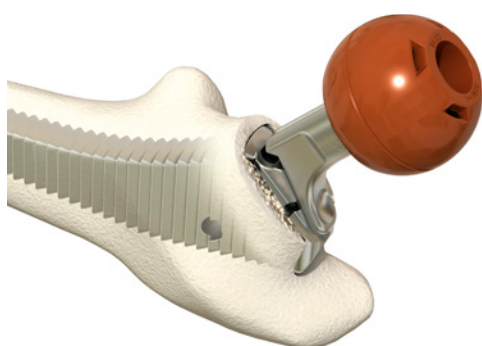
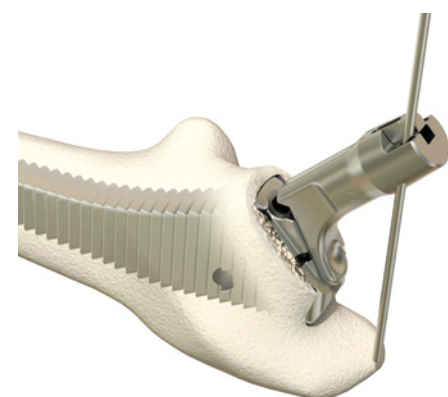
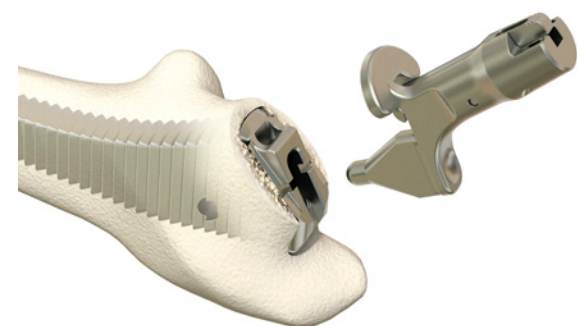
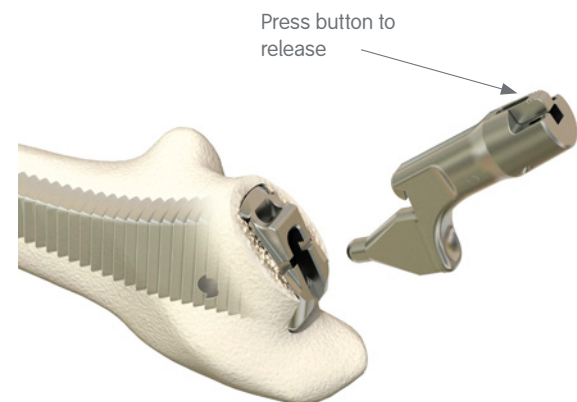

---

## Stem insertion

We recommend that the plastic protective cover on the taper is not removed until the stem is in its final position and the ball head is ready to be attached to the cone.



### Cementless stem

The femoral component is inserted using the stem impactor (75023369/21000644).

The edge of the HA coating indicates the required penetration level of the stem.

Alternatively, the stem impactor curved (75000675/21000438) can be used.

### Important note for collared stems

The POLARSTEM® follows the self-locking principle with a triple-tapered design. To avoid that the implant rests on the collar before finally seated and self-locked in the bone, a little gap of about 1mm remains between planed calcar bone and bottom side of the collar. This ensures that the collar acts as an additional safety stop against subsidence only, without compromising the primary implant anchorage philosophy.

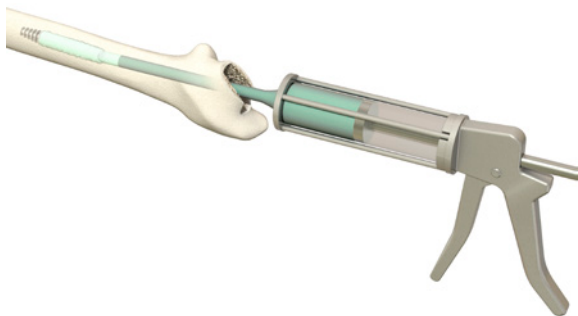

### Cemented stem

The IM canal should always be plugged using either autogenic bone material or a standard IM plug.

The cement is prepared following the cement manufacturer's instruction and retrogradely filled into the IM canal by using a cement syringe.

We recommend that the cement mantle starts 10–15 mm below the tip of the stem.

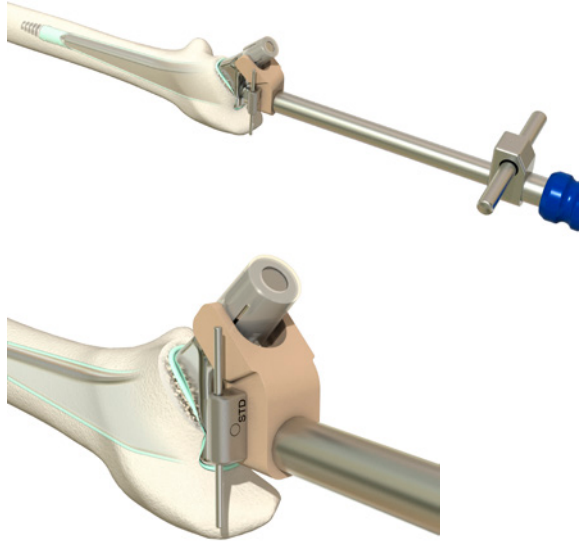

## Options for stem anchorage

### Option 1

To perform an implantation according to the **self-locking principle**, a stem of the same **size as the last rasp used** is selected.

### Option 2

To obtain a **complete cement mantle**, a stem of one to two sizes **smaller than the last rasp used** is selected.

Before insertion, the anterior thread of the stem inserter (75004650/21000300) is put into the extraction hole of the stem (position the wings on either side of the stem taper). The metal wheel at the back is then turned to fix the inserter to the stem.

**Please review the Assembly & Cleaning Instruction Lit. No. 21365.**

At this stage the CCD gauge (75004637/21000287) can be positioned onto the stem inserter (with the writing on the selected stem type – STD or LAT – is facing the observer), so that the position of the prosthesis in relation to the greater trochanter can be measured using the pin for CCD gauge (50/100 mm).

The stem is then pressed into the cement using the stem inserter. Anteversion can be checked using the bolt (75001747/1060909) and the laser marking on the stem, which corresponds to the HA limit marking on the rasp, can be used as reference line as well. The stem is held in position under slight pressure until the cement has hardened according to the manufacturer's instructions. Any excess cement should be removed.

### Important note

Cemented stems are made of stainless steel and have restrictions on material combinations (see page 5). The stem inserter (75004650/21000300) is intended to be used for cemented stems only and shouldn't be used for impaction of Ti/HA stems.

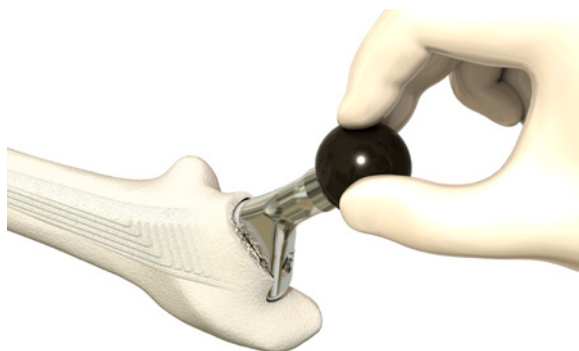

## Ball head introduction

Remove the plastic taper protection.

Before positioning the ball head, carefully wash the stem cone with water and then dry. Then position the ball head and secure in place with slight rotation.

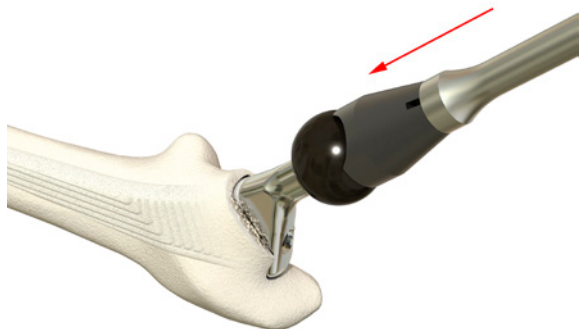

The ball head is firmly impacted using a plastic impactor (75023710/21000662, 75023711/21000663). The joint is then reduced, manipulated and retested to ensure proper functioning.

Alternatively, trial reduction can also be performed with the stem impactor.

#### Note

Please carefully read the chapter “Reliable fit of femoral ball heads on stem tapers” on page 4. Ceramic heads must never be impacted using a metal instrument. If the POLARSTEM° is used with a POLARCUP°, the ball head must first be impacted in the cup’s corresponding insert before reduction.

If the BIOLOX®OPTION femoral head is used, it must be pre-assembled with its Ti-sleeve before fitting it onto the hip stem taper (please refer to the BIOLOX®OPTION IFU). For the assembly of the OXINIUM® Ø40/44 head with a Ti-sleeve please refer to lit. no. 00788.

#### Wound closure

Reinsert the muscle tissue. Insert a subfascial and subcutaneous redon drain and close the wound with intracutaneous sutures for aesthetic reasons.

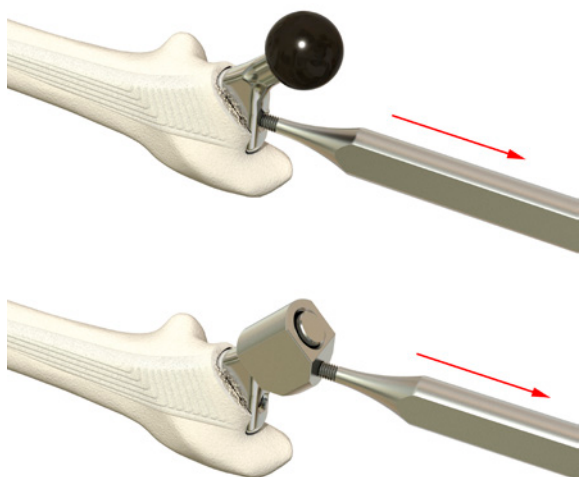

#### POLARSTEM explantation

The removal of a well-fixed prosthetic stem raises technical challenges. The objective is not only to remove the material, but also to prepare the implantation of a new prosthesis. Cemented stems are only very rarely unremovable; extraction of the cement mantle and plug raises the greatest difficulties. The main risk is cortex perforation, and a radiograph should be obtained at the slightest doubt. The removal of cementless stems carries a higher risk of fracture. Difficulties should be anticipated based on thorough familiarity with the implant design and on evaluations of implant fixation and bone stock. For more details we suggest to review ref 6.

The POLARSTEM° can be explanted using the extraction screw M6 (75002165/110249).

If this is not possible using the extraction screw, the user can also use an extractor block (75004678/21000354).

Ensure that the extraction screw is inserted axially in both cases.

The extraction screw can be used in connection with the WOODPECKER.

#### Note

In a well osseointegrated POLARSTEM cementless, the objective is to disrupt all the bone connections between the femur and stem choosing flexible, thin osteotomes with increasing width and length. Use it with the flat side to the implant. Apply lateral movement, not flexion. Use curved osteotomes for corners. K-wires may be used in addition to disrupt bone connection along the implant. When using the extraction screw M6, knock the stem in before you knock it out.

For additional stem removal tools, consider Smith & Nephew’s RENOVATION° Implant Removal System, lit no 7138-0701.

---

## Postoperative Treatment

The postoperative treatment depends on the patient's age and general state of health. The operated leg may be immediately weight bearing. For 48 hours a splint (foam) in slight abduction is recommended. The use of crutches can be helpful during the first days.

The use of antibiotics and thrombosis prophylaxis as well as suture removal are at the surgeon's discretion.

Serious incidents related to any Smith & Nephew medical device should be reported to Smith & Nephew (complaints@smith-nephew.com) and to the competent authority of the country in which the user and/or patient is established.

## Sterilization

### Implants

All the implants described in this Surgical Technique are sterile when they are delivered by the manufacturer. Resterilization is not allowed.

### Instruments

Surgical instruments and trials are not sterile when they are delivered. They are to be cleaned, inspected and sterilized before use as described in the guide "Processing (cleaning, disinfection and sterilization) of instruments from Smith & Nephew Orthopaedics AG" (Lit. No. 03389). Sterilization must also be conducted in accordance with the legal regulations and guidelines applicable in the country of use.

The Stem Insertor, 75004650 / 21000300 has a separate disassembling and cleaning instruction: Lit. No. 21365.

## References

1. Cypres A et al. Long-term outcomes of a dual-mobility cup and cementless triple-taper femoral stem combination in total hip replacement: a multicenter retrospective analysis. *Journal of Orthopaedic Surgery and Research*. 2019;14:376.
2. Klasan A et al. Ten-year follow-up of a cemented tapered stem. *Archives of Orthopaedic and Trauma Surgery*. 2018;138(9):1317–1322.
3. Fiquet A, Noyer D. "Polarsystem" dual mobility hip prosthesis and "minimally invasive surgery" (MIS). *Interactive Surgery*. 2006;1:51-5.
4. Lee PY et al. Early failure of the Polarstem total hip arthroplasty - can the Australian NJR tell us the full story? *J of Arthroplasty*. 2014;29(3):609–11.
5. Nizam I. The bikini hip replacement - surgical technique preserving vessels and deep soft tissues in direct anterior approach hip replacement. *HSOA J of Orthop Res Physiother*. 2015;1:007.
6. Laffosse JM. Removal of well-fixed femoral stems. *Orthopaedics & Traumatology: Surgery & Research*. 2016;102(1, Suppl):S177–87.

# Implants

## POLARSTEM° cementless Material Ti-6Al-4V ISO 5832-3 Cone 12/14

### Standard stem CCD 135°

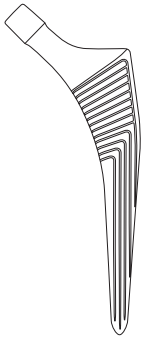

SAP No.	Size
75100462**	01
75100463*	0
75100464	1
75100465	2
75100466	3
75100467	4
75100468	5
75100469	6
75100470	7
75100471	8
75100472	9
75100473*	10
75100509*	11

#### Demo implant

75100657	3
----------	---

### Lateral stem CCD 126°



SAP No.	Size
75100474	1
75100475	2
75100476	3
75100477	4
75100478	5
75100479	6
75100480	7
75100481	8
75100482	9
75100483*	10
75100510*	11

#### Demo implant

75100658	3
----------	---

### Valgus stem CCD 145°

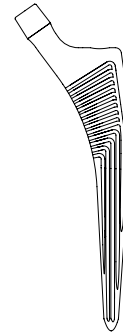

SAP No.	Size
75102072*	0
75102073*	1
75102074*	2
75102075*	3
75102076*	4
75102077*	5
75102078*	6
75102079*	7

#### Demo implant

75102216	3
----------	---

## POLARSTEM Collar

### Standard stem with collar

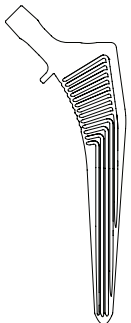

SAP No.	Size
75018399**	01
75018400*	0
75018401	1
75018402	2
75018403	3
75018404	4
75018405	5
75018406	6
75018407	7
75018408	8
75018409	9
75018410*	10
75018411*	11

#### Demo implant

75102217	3
----------	---

### Lateral stem with collar



SAP No.	Size
75018412	1
75018413	2
75018414	3
75018415	4
75018416	5
75018417	6
75018418	7
75018419	8
75102209	9
75102210*	10
75102211*	11

\* outlier sizes (optional) \*\* not available in the US



POLARSTEM® cemented Material stainless steel ISO 5832-9 Cone 12/14

Standard stem CCD 135°

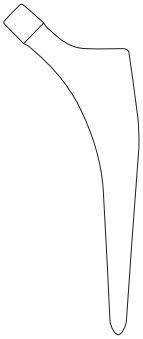

SAP No.	Item No.	Size
75002111	11000405	0
75002112	11000406	1
75002113	11000407	2
75002114	11000408	3
75002115	11000409	4
75002116	11000410	5
75002117	11000411	6
75002118	11000412	7
75002119	11000413	8

Demo implant

75000879	91000408	3
----------	----------	---

Lateral stem CCD 126°



SAP No.	Item No.	Size
75002120	11000414	1
75002121	11000415	2
75002122	11000416	3
75002123	11000417	4
75002124	11000418	5
75002125	11000419	6
75002126	11000420	7
75002127	11000421	8

Demo implant

75000880	91000416	3
----------	----------	---

# Dimensions

## Specification

			Shoulder	Resection Level		Lateral Flair Peak			Mid level of stem	
Size	Stem length I	Stem length II	1 A/P	2 M/L	2 A/P	3 L > C	3 M/L	3 A/P	4 M/L	4 A/P
01	119.5	101.5	14.2	25.6	11.9	6.8	16.7	9.5	10.0	8.1
0	125.5	107.5	14.7	27.2	12.5	8.0	18.2	10.1	10.8	8.6
1	131.5	113.5	15.2	28.7	13.0	8.7	19.7	10.7	11.9	9.1
2	135.5	117.5	15.7	30.2	13.5	9.6	21.2	11.2	13.1	9.6
3	139.5	121.5	16.4	31.5	14.2	10.2	22.2	11.9	14.4	10.4
4	143.5	125.5	16.9	32.7	14.6	10.9	23.4	12.1	15.5	10.4
5	147.5	129.5	17.5	33.9	15.1	11.5	24.5	12.3	16.6	10.4
6	151.5	133.5	18.0	35.1	15.5	12.2	25.6	12.5	17.6	10.4
7	155.5	137.5	18.4	36.2	15.9	12.8	26.6	12.6	18.6	10.4
8	159.5	141.5	18.8	36.5	16.2	13.4	26.7	12.6	19.7	10.4
9	163.5	145.5	19.3	37.3	16.9	13.9	28.1	13.6	20.7	11.6
10	167.5	149.5	19.7	37.9	17.3	14.3	29.2	13.8	21.8	11.7
11	171.5	153.5	20.1	38.5	17.6	15.2	30.7	14.4	22.8	11.7

## Neck Offset in mm for Valgus (CCD 145°) Standard (CCD 135°) Lateral (CCD 126°) - based on a 32 mm OXINIUM® head

Size	XS/-3			S/+0			M/+4			L/+8			XL/+12			XXL/+16		
01					37.2			40.0			42.8			45.7			48.5	
0	34.2	35.3		35.9	37.4		38.2	40.2		40.5	43.0		42.8	45.9		45.1	48.7	
1	35.0	37.9	40.8	36.7	40.0	43.2	39.0	42.8	46.4	41.3	45.6	49.7	43.6	48.4	52.9	45.9	51.3	56.1
2	35.7	38.5	41.5	37.3	40.6	43.8	39.6	43.4	47.0	41.9	46.2	50.3	44.2	49.1	53.5	46.5	51.9	56.7
3	36.5	39.3	42.3	38.1	41.4	44.6	40.4	44.2	47.8	42.7	47.0	51.1	45.0	49.9	54.3	47.3	52.7	57.5
4	37.1	40.0	42.9	38.8	42.0	45.3	41.1	44.9	48.5	43.4	47.7	51.7	45.7	50.5	55.0	48.0	53.3	58.2
5	37.7	40.6	43.5	39.4	42.6	45.9	41.7	45.5	49.1	44.0	48.3	52.3	46.3	51.1	55.6	48.6	54.0	58.8
6	38.3	41.2	44.1	40.0	43.3	46.5	42.3	46.1	49.7	44.6	48.9	53.0	46.9	51.7	56.2	49.2	54.6	59.4
7	39.0	41.8	44.7	40.6	43.9	47.1	42.9	46.7	50.3	45.2	49.5	53.6	47.5	52.3	56.8	49.8	55.2	60.0
8		42.3	45.3		44.4	47.6		47.2	50.8		50.0	54.1		52.9	57.3		55.7	60.5
9		43.0	46.0		45.1	48.3		47.9	51.6		50.8	54.8		53.6	58.0		56.4	61.3
10		43.7	46.6		45.7	48.9		48.5	52.2		51.4	55.4		54.2	58.6		57.0	61.9
11		44.3	47.2		46.3	49.5		49.1	52.8		52.0	56.0		54.8	59.3		57.6	62.5

## Neck Length in mm for Valgus Standard Lateral

Size	XS/-3			S/+0			M/+4			L/+8			XL/+12			XXL/+16		
01					29.9			33.9			37.9			41.9			45.9	
0	29.9	27.0		32.8	29.9		36.8	33.9		40.8	37.9		44.8	41.9		48.8	45.9	
1 - 7	29.9	29.5	29.5	32.8	32.4	32.4	36.8	36.4	36.4	40.8	40.4	40.4	44.8	44.4	44.4	48.8	48.4	48.4
8 - 12		29.5	29.5		32.4	32.4		36.4	36.4		40.4	40.4		44.4	44.4		48.4	48.4

## Neck Height in mm for Valgus Standard Lateral

Size	XS/-3			S/+0			M/+4			L/+8			XL/+12			XXL/+16		
01					26.4			29.3			32.1			34.9			37.8	
0	27.6	24.4		30.0	26.4		33.3	29.3		36.5	32.1		39.8	34.9		43.1	37.8	
1 - 7	27.6	26.2	24.7	30.0	28.2	26.4	33.3	31.0	28.8	36.5	33.9	31.2	39.8	36.7	33.5	43.1	39.5	35.9
8 - 12		26.2	24.7		28.2	26.4		31.0	28.8		33.9	31.2		36.7	33.5		39.5	35.9

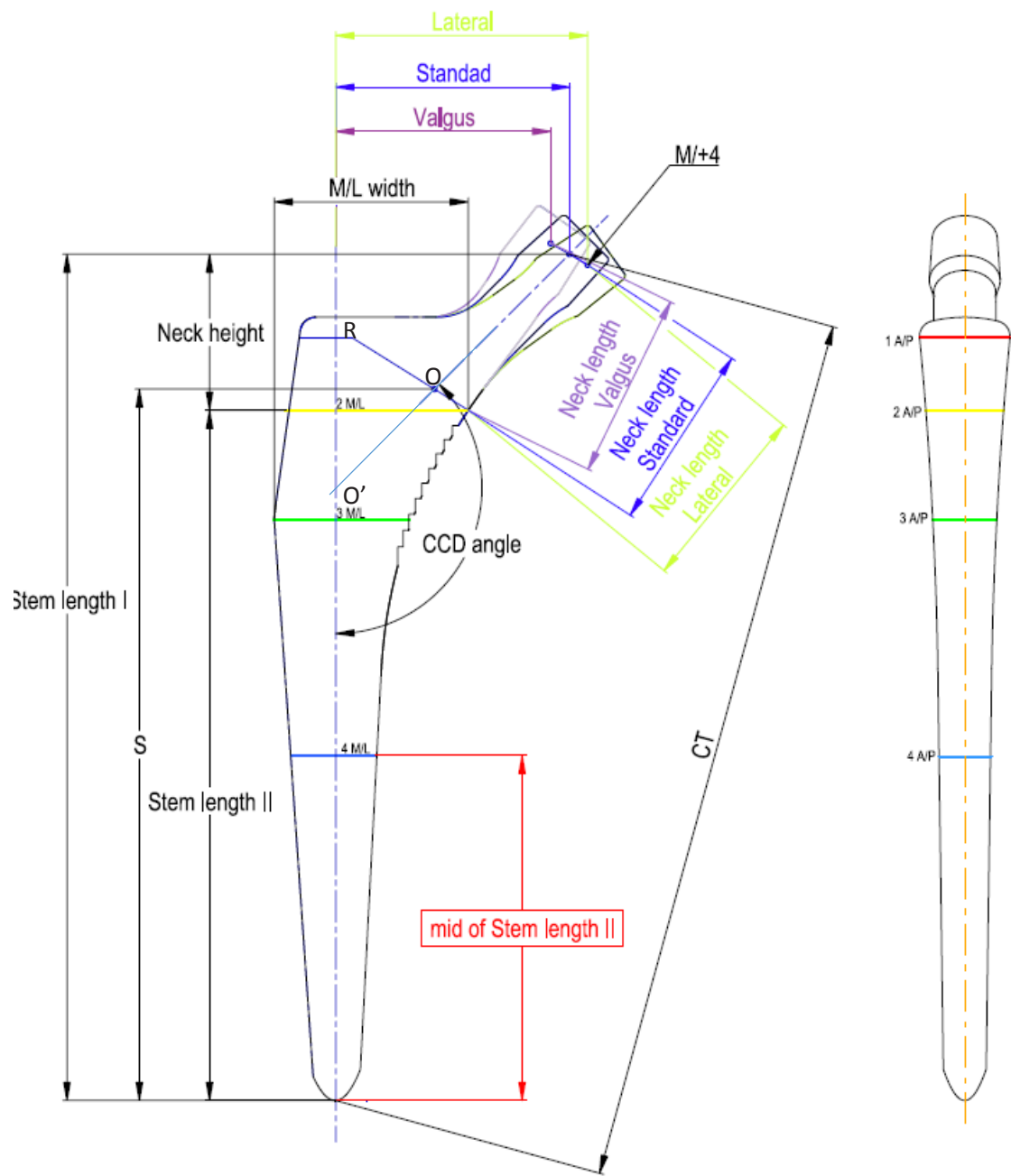

Valgus	S	CT	Standard	S	CT	Lateral	S	CT
-	-	-	O1	105.6	135.8	-	-	-
0	110.5	144.8	0	111.6	141.6	-	-	-
1	116.4	150.8	1	117.6	149.7	1	118.7	148.8
2	120.4	154.9	2	121.6	153.7	2	122.7	152.8
3	124.2	158.9	3	125.4	157.6	3	126.7	156.8
4	128.7	163	4	129.8	161.9	4	130.7	160.8
5	132.7	167	5	133.7	165.9	5	134.7	164.8
6	136.5	171	6	137.7	170	6	138.7	168.8
7	140.7	174.9	7	141.8	173.7	7	142.7	172.8
-	-	-	8	145.6	177.9	8	146.8	176.8
-	-	-	9	149.6	182	9	150.7	180.9
-	-	-	10	153.6	186	10	154.7	184.9
-	-	-	11	157.9	190	11	158.4	188.9

# Instrument Set

Set No. 75210200

	SAP No.	Item No.	Name	Size
	75100213	21000675	Basic Case	
	75007661	990019	Easy Tray Lid Plastic	
①	75004665	21000341	Hollow Chisel	
①a	75004666	21000342	Rod for Hollow Chisel	
②	75023019	21000616	Detachable Rasp	01
	75004641	21000291	Detachable Rasp	0
	75004642	21000292	Detachable Rasp	1
	75004643	21000293	Detachable Rasp	2
	75004644	21000294	Detachable Rasp	3
	75004645	21000295	Detachable Rasp	4
	75004646	21000296	Detachable Rasp	5
	75004647	21000297	Detachable Rasp	6
	75004648	21000298	Detachable Rasp	7
	75004649	21000299	Detachable Rasp	8
	75018110	21000592	Detachable Rasp	9
	75018111	21000593	Detachable Rasp	10
	75023020*	21000617	Detachable rasp	11
③	75000642	21000378	Knock Plate	
④	75001747	1060909	Bolt	
⑤	75023794	21000668	Trial Neck Standard	01
	75023370	21000645	Trial Neck Standard	0
	75004639	21000289	Trial Neck Standard	1-11
	75004640	21000290	Trial Neck Lateralized	1-11
	75102213*	75102213	Trial Neck Valgus	0-7

\*outlier size (optional)

Optional Rasp Adapters:

	Set No.	SAP No.	Item No.	Name	Size
⑥	75200166	75007307	600920	MIA Offset-Adapter	25 mm
	75200168	75007308	600921	MIA Offset-Adapter	40 mm
	75200169	75007309	600922	MIA Offset-Adapter	10 mm
	75200171	75007310	600923	MIA Offset-Adapter Left	17/13 mm
		75007311	600924	MIA OffsetAdapter Right	17/13 mm
	75210202	75004612	21000262	MIA Double Offset-Adapter Left	60/25 mm
		75004613	21000263	MIA Double Offset-Adapter Right	60/25 mm
		75102237	75102237	DAA Offset Adapter Left	80/45mm
		75102240	75102240	DAA Offset Adapter Right	80/45mm
		75004614	21000264	MIA Offset Adapter (with Plate)	45°
		75103197	75103197	DAA Offset Adapter	45°

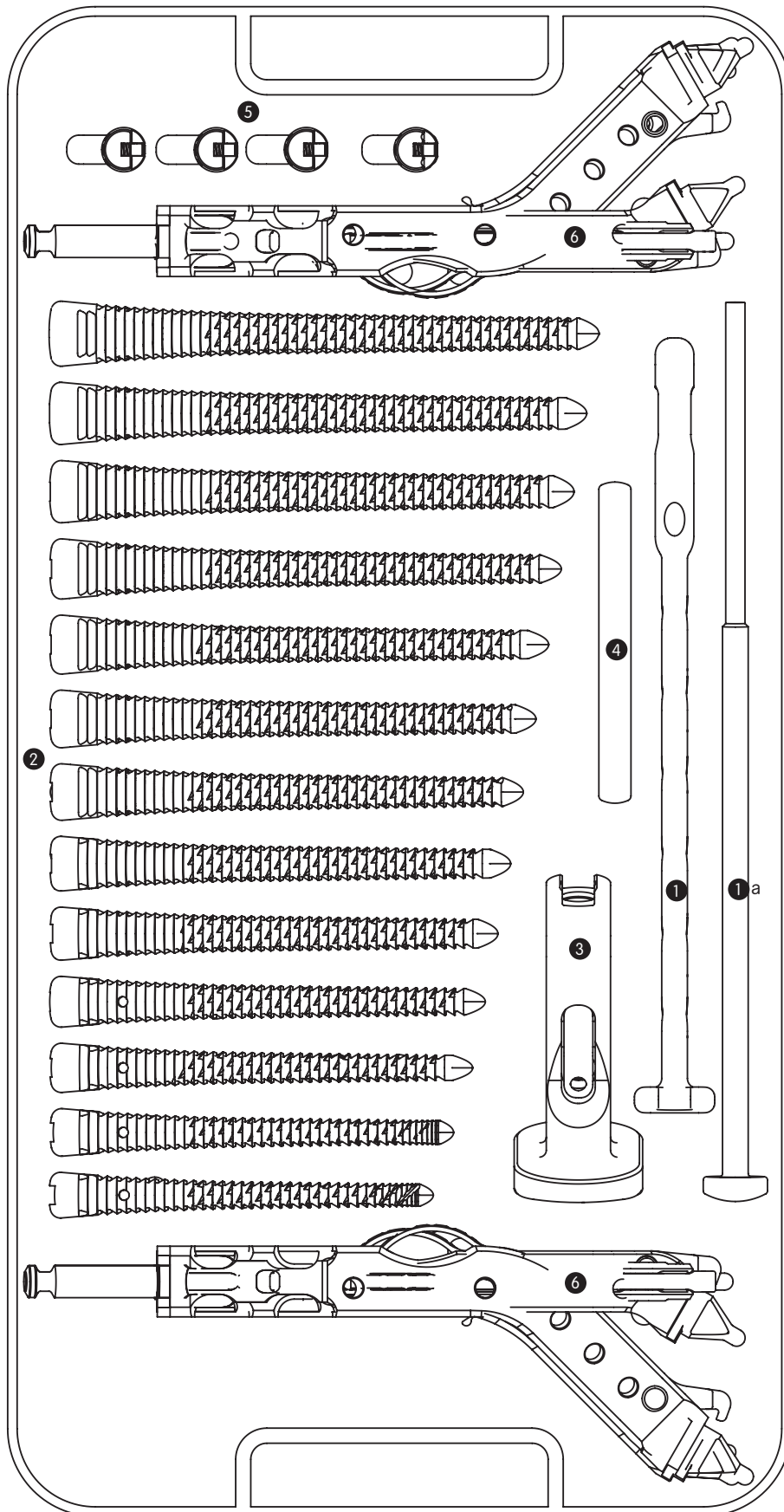

Set No. 75210200

	SAP No.	Item No.	Name	Size
	75100214	21000676	Tray to Case 21000675	
①	75004650*	21000300	Stem Inserter	
①a	75023745*	21000667	Fin Stabilizer for 21000300	
②	75100194*	21000673	Flat Wrench for 21000300	
③	75004637*	21000287	CCD Gauge	
③a	75004638*	21000288	Rod for CCD Gauge	50 mm
③a	75004664	21000340	Rod for CCD Gauge	100 mm
④	75102387	75102387	Box small, empty	
⑤	75004667	21000343	Femoral Reamer	
⑥	75023369	21000644	Stem Impactor	
⑦	75002165	110249	Extraction Screw	M6
⑧	75004678	21000354	Extractor Block	
⑨	75023710	21000662	Ball Head Impactor	
⑨a	75023711	21000663	Modular Head for 21000662	
⑩	75100839*	75100839	Trial Femoral Head	22 S/+0
	75100840	75100840	Trial Femoral Head	22 M/+4
	75100841	75100841	Trial Femoral Head	22 L/+8
	75100842*	75100842	Trial Femoral Head	22 XL/+12
	75100843*	75100843	Trial Femoral Head	28 XS/-3
	75100844	75100844	Trial Femoral Head	28 S/+0
	75100845	75100845	Trial Femoral Head	28 M/+4
	75100846	75100846	Trial Femoral Head	28 L/+8
	75100847	75100847	Trial Femoral Head	28 XL/+12
	75100848*	75100848	Trial Femoral Head	28 XXL/+16
	75100849*	75100849	Trial Femoral Head	32 XS/-3
	75100850	75100850	Trial Femoral Head	32 S/+0
	75100851	75100851	Trial Femoral Head	32 M/+4
	75100852	75100852	Trial Femoral Head	32 L/+8
	75100853	75100853	Trial Femoral Head	32 XL/+12
	75100854*	75100854	Trial Femoral Head	32 XXL/+16
	75100855*	75100855	Trial Femoral Head	36 XS/-3
	75100856	75100856	Trial Femoral Head	36 S/+0
	75100857	75100857	Trial Femoral Head	36 M/+4
	75100858	75100858	Trial Femoral Head	36 L/+8
	75100859	75100859	Trial Femoral Head	36 XL/+12

\*outlier size (optional)

\* for cemented only

Optional:

SAP No.	Art. No.	Description	Size
75210292	75210292	SET 40mm Trial Femoral Heads	XS/-4 to L/+8
75210293	75210293	SET 44mm Trial Femoral Heads	XS/-4 to L/+8
75102465	75102465	Spare Part Handle for 21000300	
75102466	75102466	Spare Part Rod for 21000300	
75102467	75102467	Spare Part Nut for 21000300	

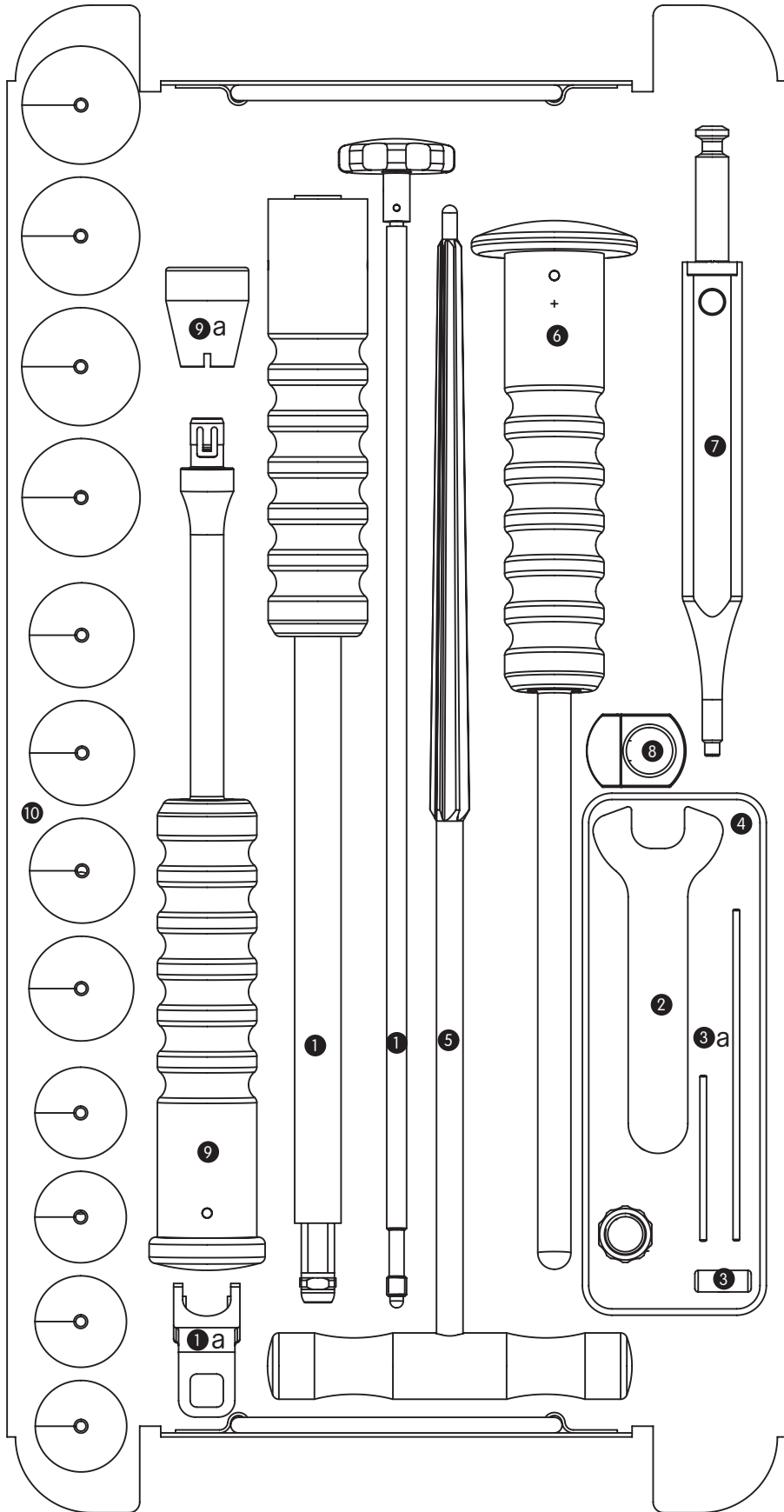

---

# Instrument Set Collar + Valgus + Add-on Instruments

## Optional

Set No. 75210301

	SAP No.	Item No.	Name	Size
	75102199	75102199	Collar Case	
	75007661	990019	Easy Tray Lid Plastic	
①	75102201	75102201	Trial Neck with Collar STD 01	01
	75102202	75102202	Trial Neck with Collar STD 0	0
	75102203	75102203	Trial Neck with Collar STD 1-11	1-11
	75102204	75102204	Trial Neck with Collar LAT 1-11	1-11
②	75102205	75102205	Calcar Reamer Guide	
③	75103199	75103199	Calcar Planer Small	
	75103200	75103200	Calcar Planer Large	
④	75000675	21000438	Stem Impactor Curved	
⑤	75102237	75102237	DAA Offset Adapter Left	80/45mm
	75102240	75102240	DAA Offset Adapter Right	80/45mm
⑥	75102238	75102238	Modular Knock plate large	
⑦	75102239	75102239	POLARSTEM® Starter Rasp	
⑧	75004495	21000138	MIA Curved Rasp	
⑨	75102213	75102213	Trial Neck Valgus	



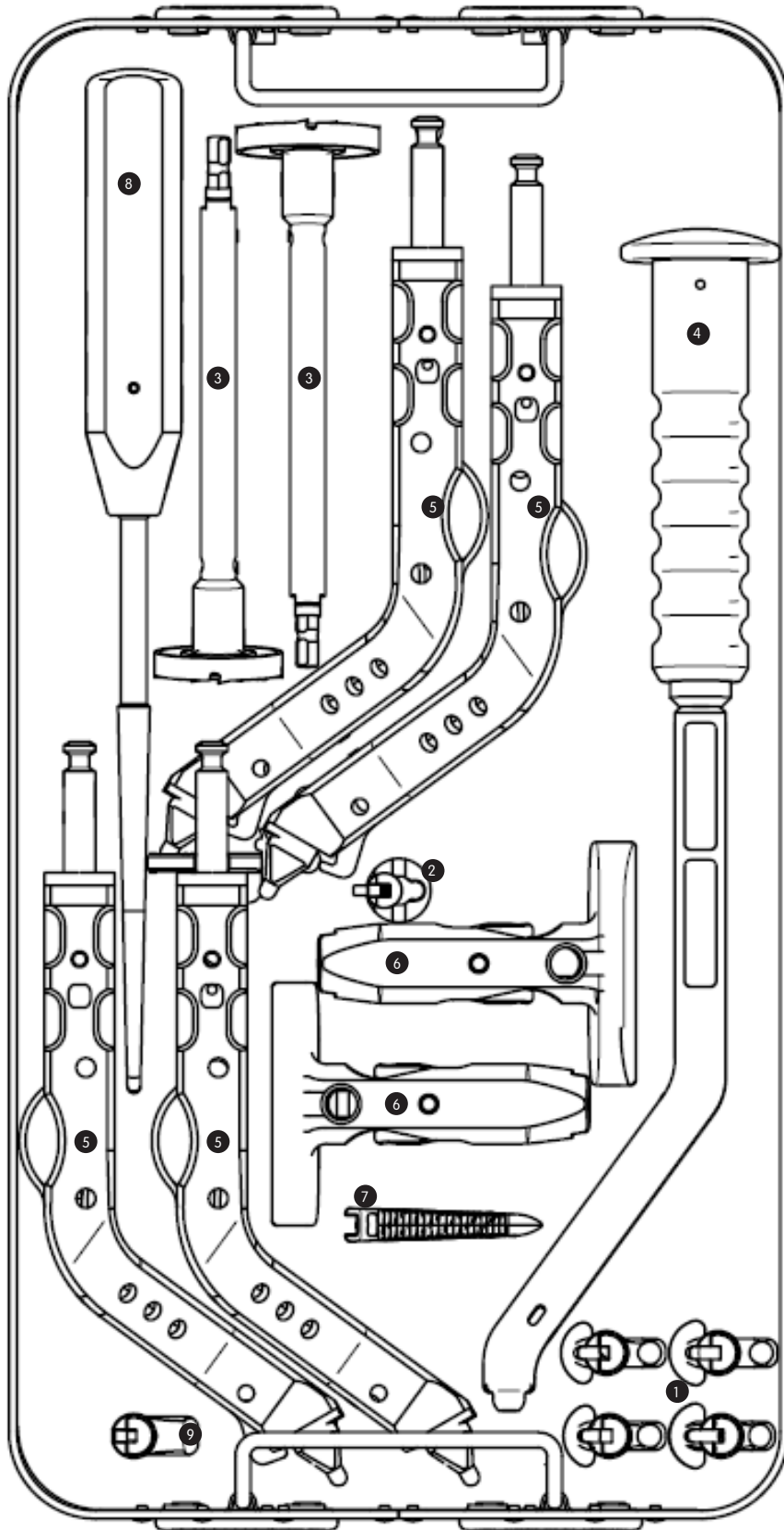





**Manufacturer**

Smith & Nephew Orthopaedics AG  
Oberneuhofstrasse 10d  
6340 Baar  
Switzerland

[www.smith-nephew.com](http://www.smith-nephew.com)

°Trademark of Smith & Nephew  
All Trademarks acknowledged  
©2021 Smith & Nephew  
01217-en V6 08/21



Supporting healthcare professionals for over 150 years