

Disassembly and cleaning instruction

Shell Impactor curved Navigation for POLARCUP[◇]
SAP/Art. No. 75000648/21000411

This disassembly and cleaning instruction is designed to supplement the existing instruction "Processing (cleaning, disinfection and sterilization) of instruments" Lit. No. 03389.

Key

1. Impactor
2. Cardan insert
3. Swivel nut
4. Adapter sleeve
5. Screwdriver (SAP/Art No. 75023818/21000670)

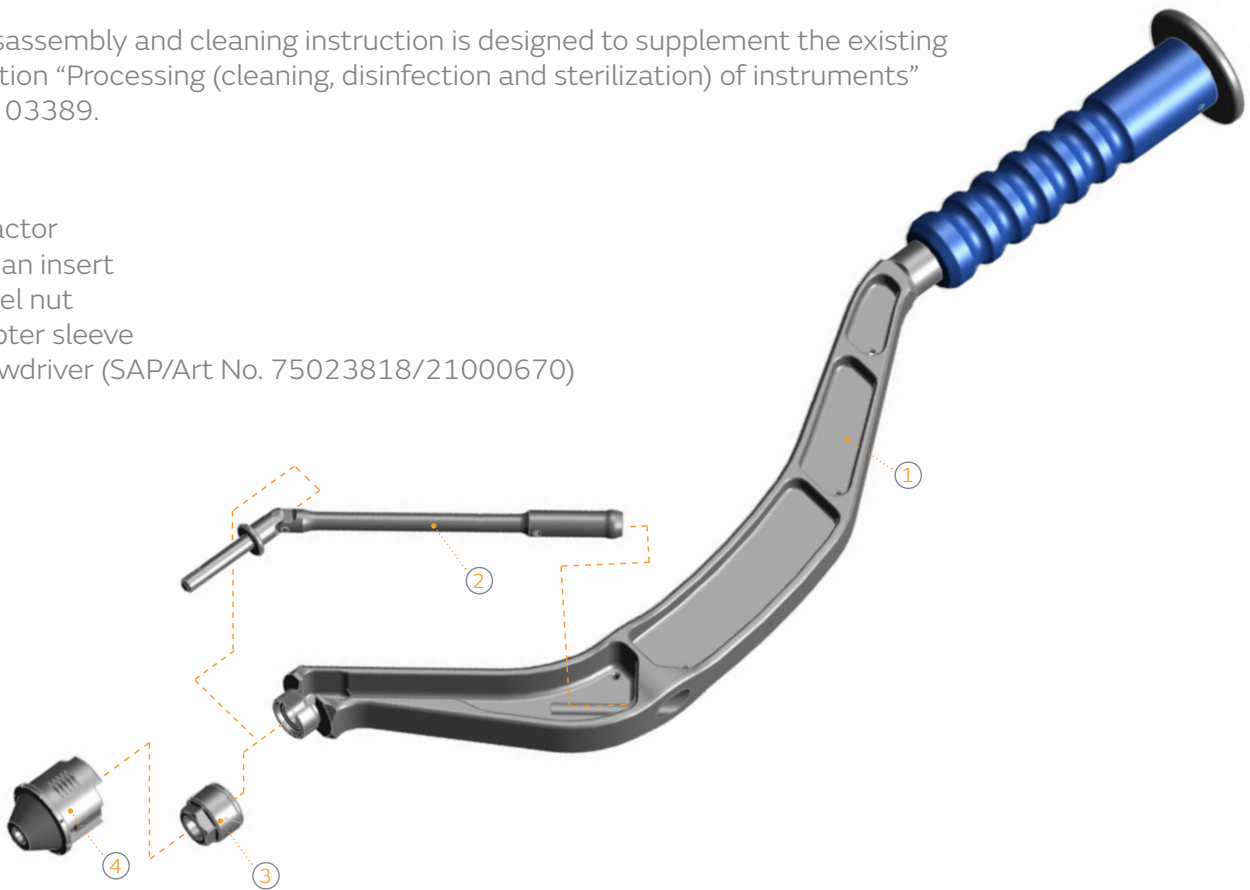

Disassembly

In accordance with the instruction "Processing (cleaning, disinfection and sterilization) of instruments" Lit. No. 03389.

The following applies in addition to or in place of the instruction:

- Remove the adapter sleeve (4) from the impactor (1)
- Loosen the swivel nut (3) with the screwdriver (5), see next page
- Pull the cardan insert (2) from the impactor (1)

Pre-cleaning

In accordance with the instruction "Processing (cleaning, disinfection and sterilization) of instruments" Lit. No. 03389.

The following applies in addition to or in place of the instruction:

- Manually pre-clean all drill holes, passages and threads

Machine cleaning and disinfection

In accordance with the instruction "Processing (cleaning, disinfection and sterilization) of instruments"

Lit. No. 03389.

The following applies in addition to or in place of the instruction:

- Please take special care to ensure that any cavities can be properly rinsed

Drying

In accordance with the instruction "Processing (cleaning, disinfection and sterilization) of instruments"

Lit. No. 03389.

The following applies in addition to or in place of the instruction:

- All drill holes and cavities can also be dried with pressurised air

Inspection and maintenance

In accordance with the instruction "Processing (cleaning, disinfection and sterilization) of instruments"

Lit. No. 03389.

The following applies in addition to or in place of the instruction:

- Check the thread for signs of damage

Assembly

In accordance with the instruction "Processing (cleaning, disinfection and sterilization) of instruments"

Lit. No. 03389.

The following applies in addition to or in place of the instruction:

- Assembly is in reverse to disassembly
- The adapter sleeve (4) should be mounted so that the laser markings are in line with the markings on the impactor (1)

