

Smith+Nephew

SMART TSF[◇]

Circular Fixator

Surgical Technique

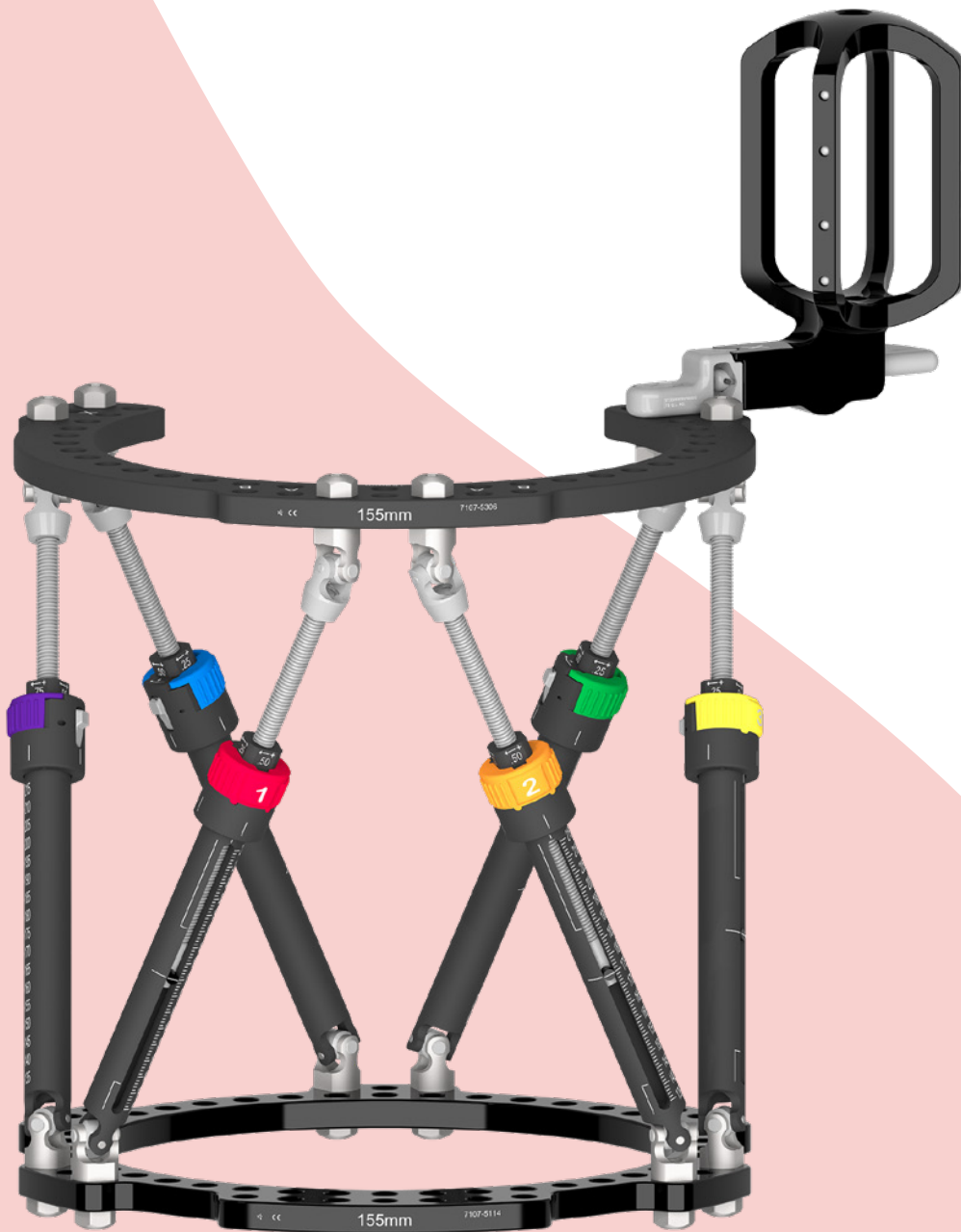

Table of Contents

System Overview	1
Constructing a Stable Frame.....	3
How to change out a Strut.....	17
Removal of TSF	18
Tray Layout.....	19
Catalog Information	27
Appendix.....	28

Note Bena

The following technique is for informational and educational purposes only. It is not intended to serve as medical advice. It is the responsibility of treating physicians to determine and utilize the appropriate products and techniques according to their own clinical judgment for each of their patients. **For more information on the SMART TSF, including its indications for use, contraindications, and product safety information, please refer to the product's label and the Instructions for Use packaged with the product.**

System Overview

Device Description

SMART TSF[®] is a Ring-based External Fixator used in the management of fractures and correction of long bone deformities.

The TSF construct consists of two Rings and six telescoping Struts in the specific configuration described in “TSF Assembly.”

The TSF is applied to bone according to Ilizarov principles.^{1,2}

HA-Coated Half Pins of 4.5mm or 6mm diameter, and Wires of 1.5mm or 1.8mm diameter connect the Rings to the bone.

Once TSF has been surgically applied, the parameters of the deformity and the details of the hardware can be entered in the web-based application SMART-TSF.com. The program will generate a prescription of Strut adjustments that reduce the angulations, rotations and translations to zero. The patient performs the Strut adjustments at a rate and rhythm determined by the surgeon. The Strut adjustments cause movement of one Ring relative to the other. The Strut adjustment schedule may last a number of weeks. Thereafter, the patient enters the consolidation phase of bone healing.

The TSF system offers the following clinical benefits:

- Early and progressive weight-bearing³⁻⁶
- Fixation in good bone with soft tissue coverage, staying away from the compromised zone of injury⁶
- Anatomic reduction and alignment can be refined post-operatively^{7,8}
- No hardware left behind after treatment
- Restoration of the mechanical axis of the limb⁹

SMART TSF components are compatible with all existing TAYLOR SPATIAL FRAME[®] Hardware. SMART TSF Software supports constructs assembled using classic TAYLOR SPATIAL FRAME Hardware. A complete list of components is detailed in the ILIZAROV[™] and TAYLOR SPATIAL FRAME Pocket Guide (Literature no 29781).



See TSF[®] and ILIZAROV[™] Hardware Pocket Guide 29781 for a full list of circular fixation components.

New Features on SMART TSF[®]

Hardware

New **Struts** with 0.25mm adjustability.

A animal study has shown that finer and frequent adjustments are conducive to optimal osteogenesis.²

Struts can be mounted to a Step-off plate, providing more options in constructs where Rings are close together.

Struts can be dynamized with the **Dynamization Kit**, which is designed to introduce controlled axial dynamization.

The **Conversion Kit** enables a static frame construct, alternative to a hexapod, by using Threaded Rods to connect Rings that are not parallel.

The **Wire Tensioner** has been re-designed to improve its handling, make calibrations more visible and eliminate need for disassembly for cleaning.

Torque Wrench handle extends away from the frame, designed to eliminate hardware collisions.

Wire Fixation Bolt combines slotted and cannulated option in one design. Hex recess enables control with the 3mm Set Screwdriver.

Software

The SMART TSF Beacon can be attached to the TSF and captured in X-ray images. When uploaded to the SMART TSF software, the Beacon serves to scale and calibrate the X-ray image. When the Beacon is used, Mounting Parameters are digitally calculated and deformity or fracture parameters can be input using digital image analysis tools now included within [SMART-TSF.com](https://www.smart-tsf.com).

There are four deformity analysis methods in SMART TSF:

1. Manual entry based on measurements taken outside of the software
2. Origin and Corresponding Point method using digital X-ray images within the software
3. **TraumaDots** – define the edge points of two bone segments on X-ray images in the software to view the digitally-reduced fracture
4. **SuperDot** – define the rotation point on X-ray images in the software and digitally restore the alignment

SMART TSF components are compatible with all existing TAYLOR SPATIAL FRAME[®] Hardware. SMART TSF Software supports constructs assembled using classic TAYLOR SPATIAL FRAME Hardware.

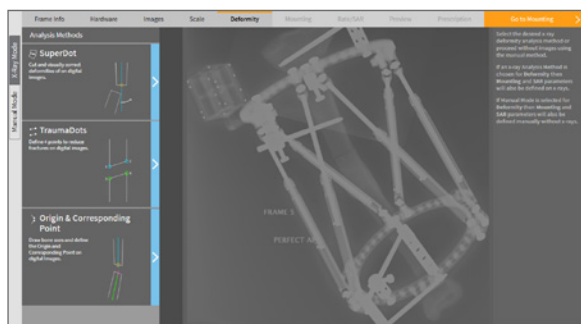
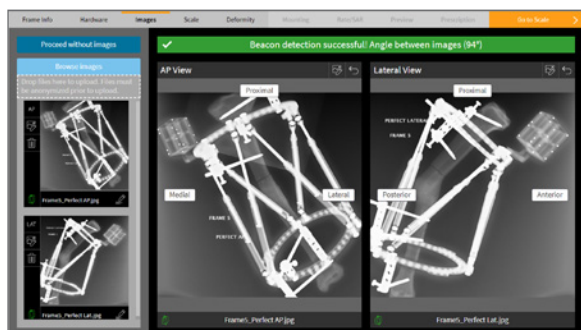

Constructing a Stable Frame

TSF[®] Rules

The shared connection points for Struts 1&2, 3&4, and 5&6 are always on the proximal Ring. The shared connection points for Struts 2&3, 4&5, and 6&1 are always on the distal Ring.

The shared connection point for Struts 1&2, located on the proximal Ring, is defined as the Master Tab.

The Master Tab is always on the proximal Ring.

The Master Tab is always directly anterior unless the rotary frame angle is a value other than zero.

Struts are always numbered in a counterclockwise manner from the patient's perspective:.

1. Red
2. Orange
3. Yellow
4. Green
5. Blue
6. Violet

Post-operative X-rays used for deformity analysis and Mounting Parameter calculation should always be taken orthogonal to the reference fragment.

If distal referencing, DO NOT flip the frame upside down. The Master tab is still on the proximal Ring.

When distal referencing, use the empty tab located between Struts 1&2 on the distal Ring as an anterior reference. This is the Anti-Master Tab.

When distal referencing, the AP and Lateral translations will be reversed. Describe the deformity in terms of the proximal fragment relative to the distal fragment.

Always describe the deformity you see; not the direction in which you want the frame to move.

Always verify the images and displayed values throughout a program prior to printing a prescription for a patient.

Deformity Parameters - "the Corresponding Point is angulated/ translated/rotated ... relative to the Origin."

Mounting Parameters - "the frame (center of the Reference Ring) is offset...relative to the Origin."



TSF^o Assembly

Option 1: Pre-Operative Assembly

Collect all six Struts and remove all Shoulder Bolts

Attach Strut #1 to the Proximal Ring, in the hole marked with a complete circle on the Ring

Attach Strut #2 to the same tab, on the other hole marked with a complete circle. The Tab where Struts 1&2 meet is defined as the Master Tab, and is always on the Proximal Ring.

On a Full Ring, skip a Tab between Strut connections. On a 2/3 Ring, all Tabs will have Struts. Struts are attached in a counter-clockwise direction, from a top-down perspective.

On the Distal Ring, the Tab opposite the Master Tab stays empty. Connect Strut #1 to the Tab adjacent to this on the Distal Ring.

Continue connecting Struts 2 through 6 in this pattern, skipping a Tab on Full Rings, and filling all Tabs on 2/3 Rings.

Struts can be positioned either threaded rod end up or down, determined by how the patient will optimally view the scale on each Strut.

All twelve shoulder Bolts should be tightened with Torque Limiting Wrench 71075410.

Identify Struts #1 through #6 by placing the sterile-packed colored ID Band on each one, and the ID Cap on the Shoulder Bolts that the patient will see. This can be done before attaching the frame to the limb to help orient the construct.

Struts can be re-positioned intra-operatively if required. The holes included within the dashed line boundaries indicate where Custom Strut Mounting is available.

All mating connections should be tightened securely once fixation has been achieved. It is good practice to confirm all connections are tightened before the patient leaves the OR.

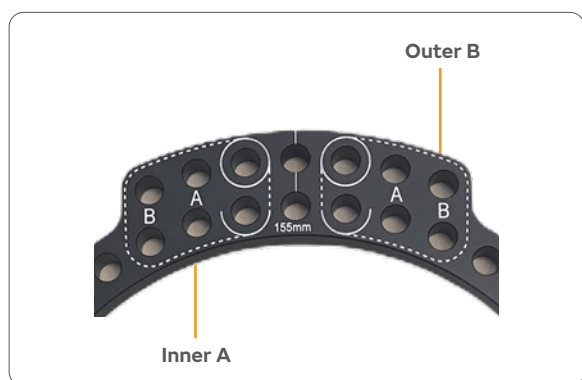
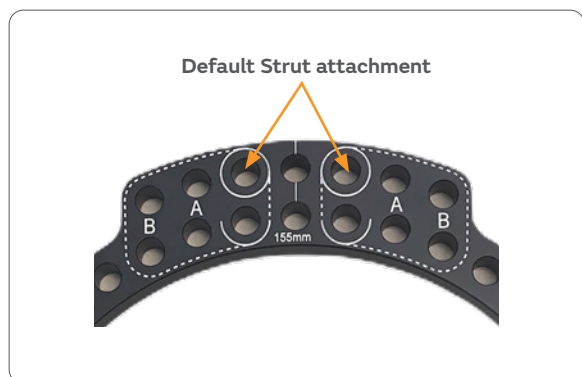

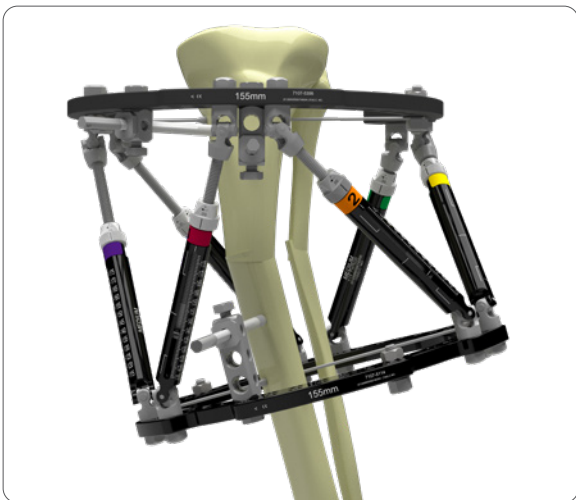
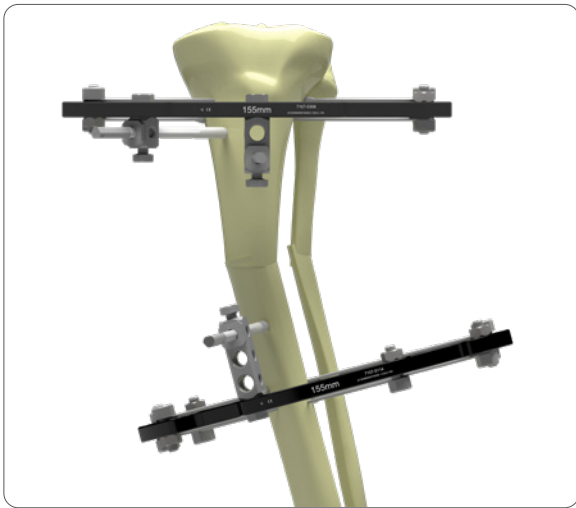

Option 2: Rings First Method

Rings are secured to bone with at least 3 points of fixation each. A Ring block provides greater stability. A Ring block is two Rings per segment with at least two points of fixation per Ring.

Ring blocks can obscure detection of the Beacon on X-ray. For optimal Beacon detection, attach the Beacon Mount to a Ring that is not part of a Ring block.

The Master Tab will be defined by the connection of Struts 1&2 on the Proximal Ring.

On Full Rings an empty Tab will occur between Tabs with Struts. On 2/3 Rings, all Tabs have Struts connected.

Struts are connected in a counter-clockwise sequence from the patient's perspective.

Struts can be positioned with the threaded rod end up or down, determined by how the patient will optimally view the scale on the Strut.

Once all Struts are connected, tighten the twelve Shoulder Bolts using Torque Wrench 71075410.

Place the ID Bands on each Strut as indicated in the diagram.

Complete the TSF[®] construct by adding additional fixation to the Rings.

All mating connections should be tightened securely once fixation has been achieved. It is good practice to confirm all connections are tightened before the patient leaves the OR.

ATLAS
FOR THE INSERTION
OF TRANSOSSEOUS WIRES
AND HALF-PINS
ILIZAROV METHOD



Refer to the Atlas for the Insertion of Transosseous Wires and Half-Pins for appropriate placement of fixation for TSF at each anatomical level.





Wire Fixation Bolt

Catalog No.	Description
71075284	Wire Fixation Bolt
71075283	Wire Fixation Bolt Long

Unit of Measure: each

Function: Used with 10mm Nut to secure a Wire to a TSF[®] Ring. Compatible with 1.5mm – 1.8mm Wires. Long used when a washer is present.

If the Wire lands centered on a hole on the Ring, use the center cannulation of the Wire Fixation Bolt to capture the Wire.

If the Wire lands to one side of a hole, use the eccentric slot of the Wire Fixation Bolt to capture the Wire.

Hand tighten a 10mm Nut (103300) onto the threads of the Bolt on the opposite side of the Ring from the Wire.

Secure Wire in place by tightening the 10mm Nut with a 10mm Wrench while holding the head of the Bolt stationary with another 10mm Wrench.

Alternatively, the 3mm Set Screwdriver (112717 or 112719) can be used to capture the hex recess on the Wire Fixation Bolt, while tightening the Nut.

Note the 3mm Set Screwdriver should not be used for the Russian tensioning method. A pair of 10mm Wrenches are more appropriate for Russian tensioning.

Wire Tensioner

Catalog No.

Description

71075341	SMART TSF [®] Tensioner
71075342	SMART TSF Tensioner Standard Modular Attachment
71075343	SMART TSF Tensioner Wrench Modular Attachment

UoM: each

Function: Tension Wires of diameter 1.5mm to 1.8mm

Secure Wire to the Ring using Wire Fixation Bolt + 10mm Nut on both sides.

Secure one side using 2 x 10mm Wrenches. For Olive Wires, tighten the side where the Olive lies first.

The Wrench Modular Attachment removes the need for an additional Wrench to stabilize the Bolt. It requires full surface contact with the Ring.

The Standard Modular Attachment should be used for tensioning a Wire on a post or corner of a tab, where full contact of the Wrench Attachment is not possible.

Choose Tensioner Modular Attachment.

Attach by opening the latch on the Tensioner and securing the Modular Attachment.

Ensure Tensioner is fully open – turn the T-handle counter-clockwise until hard stop.

Tension from the side of the Wire that has not been tightened fully to the Ring.

Insert Wire through the cannulation of the Tensioner and advance until the jaws or prongs contact the Ring or other fixation hardware.

Apply tension to desired level by turning the T-handle in a clockwise motion and reading the tension level from the laser-marked scale toward the rear of the device.

The scale is marked to indicate a tension range from 50 to 130 kg. Wires are tensioned according to surgeon's judgment, considering patient's weight, bone quality and type of wire.

Tighten the Wire to the Ring on the side being tensioned using a 10mm Nut on the Wire Fixation Bolt.

Open the Tensioner jaws fully by turning the T-handle counter-clockwise until hard stop.

Remove the Tensioner from the Wire.

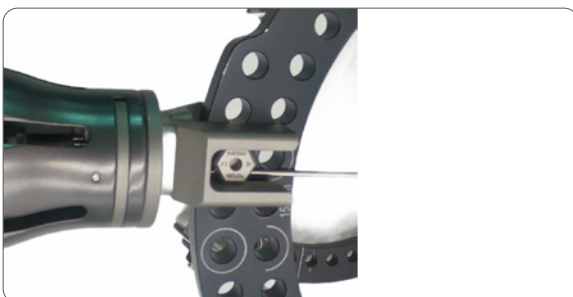



Extended HA Coated Pins

Catalog No.	Description
71076520 – 71076570	6mm x 150mm Length with Thread 15mm – 70mm
71076020 – 71076090	6mm x 200mm Length with Thread 15mm – 90mm
71074510 - 71074550	4.5mm Thread 10mm – 50mm with 6mm Shank

UoM: each, Sterile

Function: Attach TSF to Bone

Pre-drill the bone using 4.8mm Drill for 6mm Pin, 3.8mm Drill for 4.5mm Pin.

Use Pin Driver 71050031

Use a Rancho Cube or Adjustable Pin Fixation Clamp of required height to connect the Pin to the Ring.

Centralize the Pin using a 6mm Centering Sleeve in the Rancho.

Secure the Pin with a Set Screw (112727) or 8mm Bolt (100550) in the Centering Sleeve.

Tighten the construct using 13mm Wrench and 10mm Wrench.

HA Pins can be cut with HA Pin Cutter 71070849.

HA Pins can be capped with Pin Cap 71070290.

5-6mm Pin Stopper (71075295) can be used to secure an ILIZAROV[™] Sponge (102140) around the Pin at the pin site.



HA Pin T-Handle
71050031



4-6mm Pin Cutter
71070849



Wire Stopper
71075295



ILIZAROV[™] Sponge
102140



6mm Pin Caps
71070290

Conversion Clamp

Catalog No.	Description
71078550	Conversion Clamp

UoM: Box of 2 Sterile

Function: Connect two Rings that are not parallel with Threaded Rods

Secure a Ring or Ring block to each bone segment with Pins or Wires as per standard technique.

Insert the threaded post of Conversion Clamp through any hole on a TSF[®] Ring. The Conversion Clamp can be oriented to face in or out.

Secure with a 10mm Nut (103300) and hand-tighten.

Connect a 6mm Threaded Rod to the Clamp by pushing it against the black translating top jaw of the Clamp. If the top jaw is not moving freely, back off the retained nut of the Clamp a few turns.

Connect the Threaded Rod on the opposing Ring using either two 10mm Nuts (one above and one below the Ring), with or without Conical Washers (201700), or another Conversion Clamp.

Once the Clamp with Threaded Rod is positioned as desired, the Clamp must be tightened to the TSF Ring and the jaws of the Clamp must be tightened on the Threaded Rod.

Tighten the Clamp to the Ring with a 10mm Nut using a 10mm Wrench. A 10mm Wrench can also be used to hold the base of the Conversion Clamp to keep it from rotating while tightening. Alternatively, if crowding prevents access to the Clamp with a Wrench, the 90 degree 3mm Set Screwdriver (112717) can be used to stabilize the Clamp while securing the Nut.

Tighten the jaws of the Clamp onto the Threaded Rod by tightening the retained nut of the Clamp using a 10mm wrench. Do not over-tighten the Clamp on the Threaded Rod. Holding the Wrench near the Nut prevents inadvertent over-tightening.

The final frame construct is two Rings (or two Ring blocks) connected by four Threaded Rods. Connecting the Threaded Rods with the Conversion Clamp removes the constraint of requiring the Rings to be parallel to each other. Conversion Clamps also help connect Rings of different diameter.

The conversion can be performed on a frame with Struts as an out-patient procedure.

Apply four (4) Threaded Rods to one Ring, choosing a length that reaches the Ring on the other side of the deformity. Space the Threaded Rods evenly around the circumference.

Attach a Conversion Clamp to each Threaded Rod.

Insert the post of each Conversion Clamp to the Ring and secure with a 10mm Nut (103300).

Tighten all components tight using 2 x 10mm Wrenches.

Once the frame is stabilized by four Threaded Rods, the six Struts can be removed.



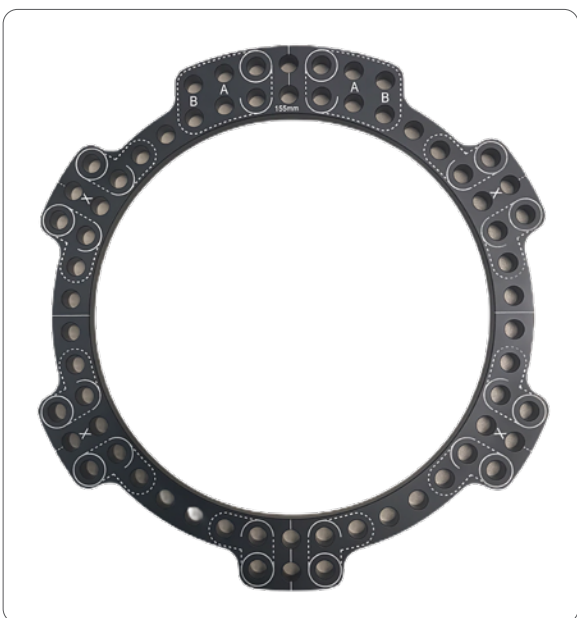

SMART TSF[®] Rings

Catalog No.	Description
71075112 – 71075117	Full Rings 105mm – 230mm
71075132	2/3 Ring 105mm – 230mm
71075127	
71075306 – 71075309	
71075123 – 71075127	Half Rings 130mm-230mm
71075302 – 71075305	U Ring 105mm – 180mm
71075144	Foot Ring 155mm and 180mm Long
71075145	
71075154	Foot Ring 155mm and 180mm Short
71075155	

Some Ring sizes are available in Purple, Red and Blue. See TSF and ILIZAROV Pocket Guide 29781 for a list of Catalog Items.

UoM: each

Function: A TSF is made up of two Rings and six Struts. SMART TSF Rings have additional markings to indicate where the Beacon Mount can be placed as well as to denote Custom Strut Mount options.

Rings are attached to bone using Half Pins and Wires.

Full Rings are the most rigid Ring type.

Ring Blocks – meaning two Rings per bone segment joined by Threaded Rods or Sockets – are more stable than single Rings.

Two Half Rings make a Full Ring. Half Rings can also be used to close a Foot Ring and capture fixation on the dorsal surface of the foot.

2/3 Rings have an opening to permit flexion.

Foot Rings match the anatomy of the foot. The opening of the Foot Ring should be bridged with hardware before applying tension to the Wires through the metatarsals.

U-Rings are used in pairs to configure a Butt Frame. They can also be used as a Foot Ring on small anatomy.

Rings should be mounted such that two finger-breadths of clearance is maintained between the inner diameter of the Ring and the soft tissue.

The tabs on the Rings are designated connection points for Struts. Markings indicate where Struts can be connected.

Markings at NE, NW, SW, SE indicate where the Beacon Mount can be placed, assuming 0° of Rotary Frame Offset. Equator lines indicate the mid-point of the Ring.

See Appendix for larger image indicating where the Beacon Mount can be placed on TSF Rings without these additional markings.

SMART TSF[®] Beacon Mount

Catalog No.

71075554

Description

SMART TSF Beacon Mount

UoM: each

Function: The Beacon Mount designates the positioning of the Beacon for X-ray capture.

NOTE See SMART TSF Web Application User Manual for detailed information on how the Beacon interacts with the SMART TSF Software.

The most important consideration for placement of the SMART TSF Beacon is that it should not be placed in the direct anterior or lateral view. The Beacon functions optimally when detected at an angle. Suggested locations are at the corners, between AP and Lateral views.

At the time of surgery, the Surgeon will designate the Beacon mounting position by placing a Beacon Mount on one Ring. The Beacon Mount stays in this position throughout treatment. If it must be re-positioned, then both AP and Lateral X-rays should be re-taken.

The Beacon Mount must be attached to the Reference Ring. The Beacon Mount requires two holes for rotational stability, and therefore can only be positioned on a tab on Full and 2/3rd Rings, and designated two-hole positions on Foot and U Rings. Furthermore, correct software recognition of the Beacon assumes the location to be in the center two holes of the tab. The 'X' laser-marks on SMART TSF Rings indicate options for Beacon Mount locations, assuming 0° Rotary Offset. These marks are on the corner tabs of Full Rings, and corresponding holes on 2/3, Foot and U Rings.

Choose a location on the Shoulder Bolt side of the Ring, to minimize interference of Struts on X-ray.

For double-stacked frames, two Beacon Mounts will be used – one on each of the most proximal and most distal Rings.

The Beacon Mount cannot be placed immediately adjacent to a Step-Off Plate, due to the footprint of each component.





SMART TSF[®] Beacon

Catalog No.	Description
7107555	SMART TSF Beacon

UoM: each

Function: The Beacon serves as a marker to calibrate and scale X-ray images.

NOTE See SMART TSF Web Application User Manual for detailed information on how the Beacon interacts with the SMART TSF Software.

The most important consideration for placement of the Beacon is that it should not be placed in the direct anterior or lateral view. The Beacon functions optimally when detected at an angle. Suggested locations are at the corners between direct AP and Lateral views.

At the time of surgery, the Surgeon will designate the Beacon mounting position by placing a Beacon Mount on one Ring.

At the time of X-ray, the X-ray technician will attach the Beacon to the Beacon Mount.

Insert the Beacon into the Beacon Mount and turn the wing through $\frac{3}{4}$ turn to lock in place. The arrow on the wing will point to "LOCK."

The Ring with the SMART TSF Beacon attached will be defined as the Reference Ring. Capture AP and Lateral X-rays with respect to the reference fragment. At least one of the images should be a true orthogonal view of the anatomy. SMART TSF software allows selection of either AP or Lateral image as the best-oriented image for analysis.

Ensure to capture the Beacon and the anatomy in the X-ray view.

Successful detection of the Beacon in SMART TSF Software depends on at least 12 of the 16 beads being captured on the X-ray image.

Once X-ray images are captured, the Beacon can be removed. The Beacon Mount is never removed.

The Beacon can be surface-cleaned with disinfectant wipes. It should not be steam-sterilized or autoclaved. When not in use the Beacon should be kept safe in the protective foam-lined case provided.

SMART FX[®] Struts

Catalog No.	Description
71075705	SMART FX Strut X-short
71075710	SMART FX Strut short
71075720	SMART FX Strut medium
71075730	SMART FX Strut long
71075040	SMART FX ID Bands

UoM: each

Function: Six (6) SMART FX Struts are used to construct the SMART TSF assembly. Struts are adjusted post-operatively by the patient according to a prescription generated in the SMART TSF web-based software. Strut Adjustments cause one TSF Ring to be moved relative to the other and drive the gradual correction of the bone. SMART FX Struts can be acutely adjusted only by the surgeon in the OR.

The Acute Adjustment Band keeps the Strut in fully adjustable mode. Removing the band puts the Strut in gradual mode. Acute adjustability can still be achieved by pressing the acute adjustment button or re-attaching the Acute Adjustment Band. The ID Band covers the acute adjustment button to prevent the Strut being inadvertently adjusted acutely outside of the OR. Gradual adjustments are performed by turning the patient adjustment dial.

SMART FX Struts have a mm scale on the body. The end of the scale indicates the 0.25mm position

The Strut adjusts in 0.25mm increments read from the four flat faces in line with the mm scale. The arrow indicates the direction to turn in order to extend the Strut, the opposite direction will shorten the Strut.

Struts can be oriented up or down or a combination. Struts are connected to tabs on the Ring. Complete circles indicate default mounting location. Dashed circles indicate optional positions and can be defined in the Software. Struts can also be connected to Step-off Plates.

Struts are connected to Rings or Step-off Plates with Shoulder Bolts. Shoulder Bolts are tightened using the Torque Wrench.

ID Bands designate the Strut number and prevent the patient from performing an acute adjustment.

The ID Band is a key component of the Strut that prevents acute adjustment. Adjustments under tension must be made with the ID Band in place.

All Acute Bands must be replaced with the definitive ID Band before the patient leaves the OR.

The Strut should be clicked into one of the quarter mm positions before attaching the ID Band. If the ID Band is not sliding easily into position, adjust the Strut by one or two quarter turns.

The ID Band can be removed with 90° Set Screwdriver (112717). Insert the tip in the notch of the ID Band and slide straight out.

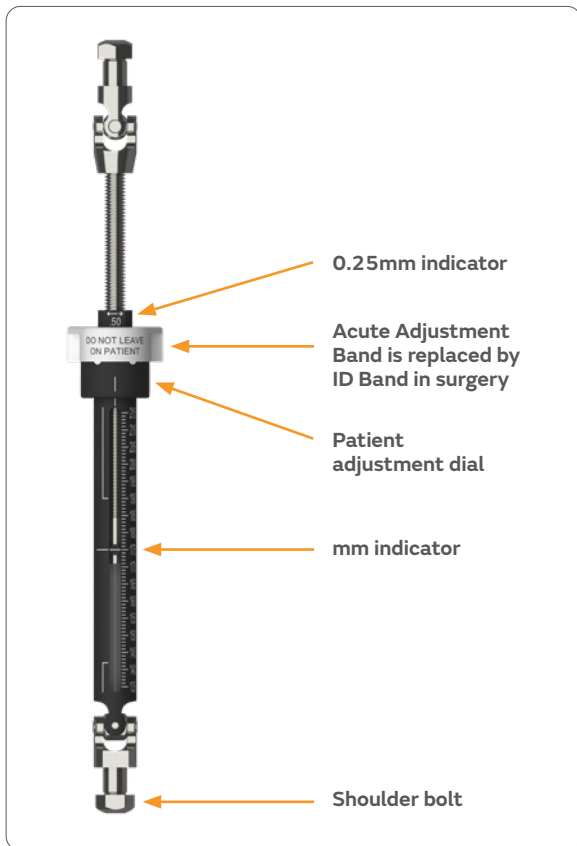

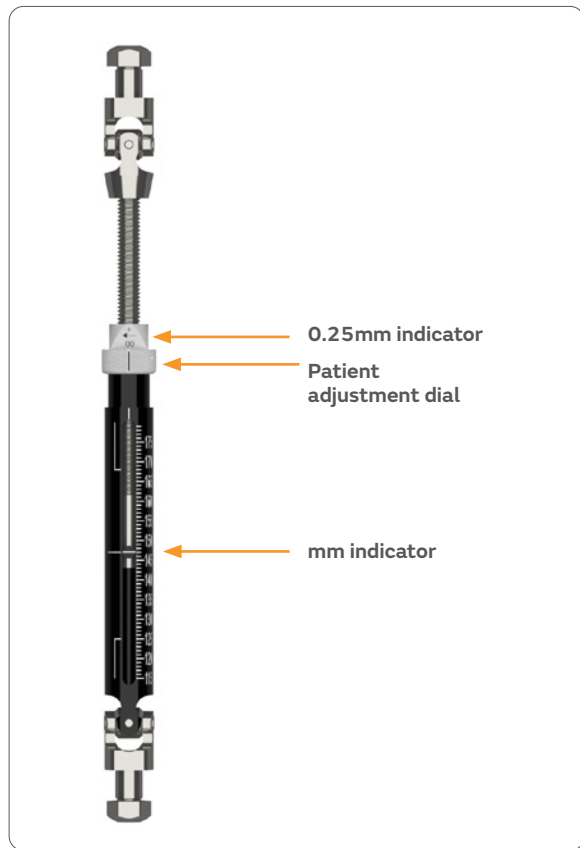

SMART Standard Struts

Catalog No.	Description
71075200	SMART Standard Strut XX-short
71075205	SMART Standard Strut X-short
71075210	SMART Standard Strut short
71075220	SMART Standard Strut medium
71075230	SMART Standard Strut long
71075050	SMART Standard ID Bands

UoM: each

Function: Six (6) Struts are used to construct the SMART TSF assembly. Struts are adjusted post-operatively by the patient according to a prescription generated in the SMART TSF web-based software. Strut Adjustments cause one TSF Ring to be moved relative to the other and drive the gradual correction of the bone.

SMART Standard Struts are adjusted gradually only, and have no acute adjustment mode.

SMART Standard Struts have a mm scale on the body. The end of the scale indicates the 0.25mm position

The Strut adjusts in 0.25mm increments read from the four flat faces on the adjustment nut. The arrow indicates the direction to turn in order to extend the Strut, the opposite direction will shorten the Strut.

Struts can be oriented up or down or a combination. Struts are connected to tabs on the Ring. Complete circles indicate default mounting location. Dashed circles indicate optional positions and can be defined in the Software. Struts can also be connected to Step-off Plates.

Struts are connected to Rings or Step-off Plates with Shoulder Bolts. Shoulder Bolts are tightened using the Torque Wrench.

ID Bands and Caps (71075050) designate the Strut number.



ID Band Kit

Catalog No.	Description
71075040	SMART FX ID Band Kit
71075050	SMART Standard ID Band Kit

UoM: 6 Bands + 6 Caps Sterile

Function: ID Bands and Caps designate the Strut number by color and number 1 to 6.

NOTE The SMART FX ID Band serves to prevent acute adjustment of the SMART FX Strut. The patient should not remove an ID Band.

ID Bands are attached to the Strut body. ID Caps fit into the hex recess in the top of the Shoulder Bolt and should be placed where the patient can see them when looking down on their frame.

Struts are numbered 1 through 6 in an anti-clockwise direction from the patient's perspective.

The tab where Struts 1&2 join defines the Master Tab. The Master Tab is always proximal.

If the Master Tab is over the anterior cortex, Rotary Frame Angle is zero.

1. Red
2. Orange
3. Yellow
4. Green
5. Blue
6. Violet



Step-off Plates

Catalog No.	Description
71075275	Step-off Plate Neutral
71075285	Step-off Plate 30mm

UoM: each

Function: Attach a Strut offset from the Ring.

Step-off Plates need two holes to achieve rotational stability and can be placed on tabs where Struts would ordinarily connect.

Position the Step-off Plate on the Ring and secure with a 10mm Nut (103300). Hand tighten.

Tighten the Nut on Step-off Plate to tab with a 10mm Wrench.

Attach the Strut to the Step-off Plate using the Shoulder Bolt, in the same way it would be attached to a Ring.

Tighten the Shoulder Bolt on Strut with the Torque Wrench.

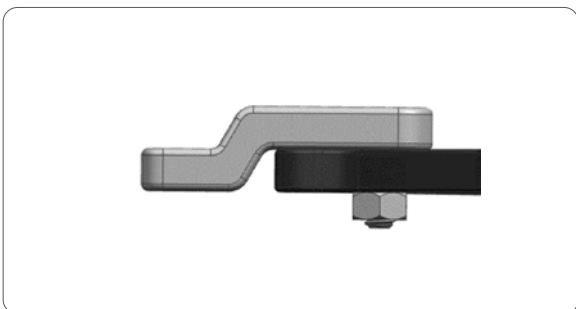

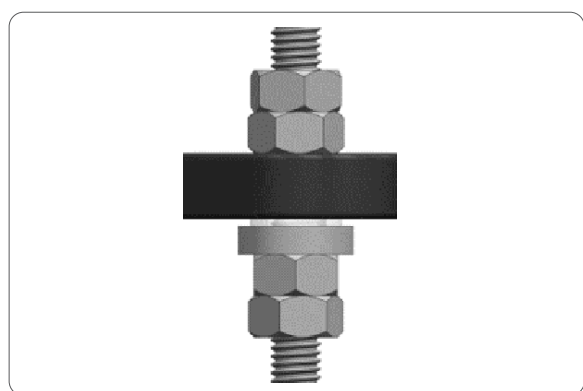

Dynamization Kit

Catalog No.	Description
71075315	Dynamization Kit

UoM: Sterile kit contains 6 Washers and 6 Long Shoulder Bolts
Function: Add to a Strut to allow controlled axial dynamization.

Dynamization should be applied to the most orthogonal Ring in order to generate axial motion in line with the mechanical axis of weight-bearing.

Attach the Frame Stabilizer assembly to the TSF to act as a 7th Strut. See page 17 for more information about the Frame Stabilizers.

Remove Shoulder Bolt from one Strut adjacent to the Frame Stabilizer.

Replace with one Long Shoulder Bolt and Dynamization Washer.

Silicone face of Washer should contact the Ring and the metal face of the washer should contact the Strut clevis. The Strut will need to be shortened to accommodate the Dynamization Washer.

Tighten the long Shoulder Bolt with the Torque Wrench (71075410) and a 10mm Open Wrench (71075905).

Moving the Frame Stabilizer to appropriate locations, repeat this process for every Strut on the Ring to be dynamized until all 6 are complete.

Remove the Frame Stabilizer assembly.

Note the Shoulder Bolt in the Dynamization Kit is longer than the standard Shoulder Bolt. It is readily identified by the black circle on the top of the bolt.

Dynamization Washer

Catalog No.	Description
71075316	Dynamization Washer

UoM: Box of 4 Sterile
Function: Add to a Threaded Rod to allow controlled axial dynamization

Orient the Dynamization Washer such that the silicone surface contacts the Ring on the inside of a frame construct (washer must be between the Rings – below the proximal Ring or above the distal Ring).

Place two 10mm Nuts (103300) against the metal surface of the Dynamization Washer and tighten those two Nuts against one another with 10mm Wrenches to hold the Washer in the desired position.

Place two 10mm Nuts on the opposite side of the Ring from the Dynamization Washer (outside the frame construct – above the proximal Ring or below the distal Ring) and tighten those two Nuts against one another with 10mm Wrenches to hold the Ring in the desired position without compressing the silicone part of the Dynamization Washer.

How to change out a Strut on TSF[®]



Catalog No.	Description
71070343	Frame Stabilizer
71062300	300mm Bar
L202002	10mm Wrench

The Frame Stabilizer Tools are designed to temporarily stabilize a frame while a Strut is removed and replaced.

The SMART TSF Clinic Set facilitates this procedure in an out-patient setting.

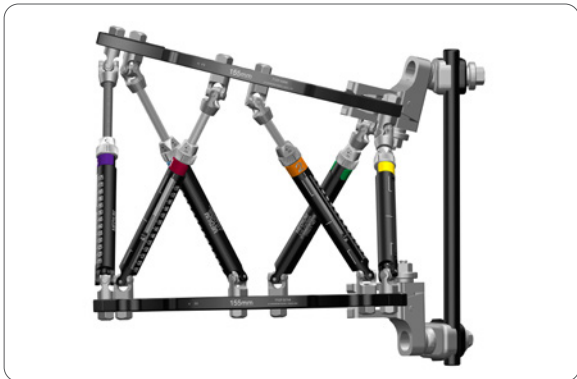

Select a tab close to the Strut being swapped on each Ring. Connect one Frame Stabilizer to the chosen tabs.

Connect the Frame Stabilizers with the 300mm Carbon Fiber Bar. Tighten the nuts on the Frame Stabilizers with a 10mm Wrench.

ID Bands should not be removed from SMART FX Struts until the Frame Stabilizer assembly is secured.

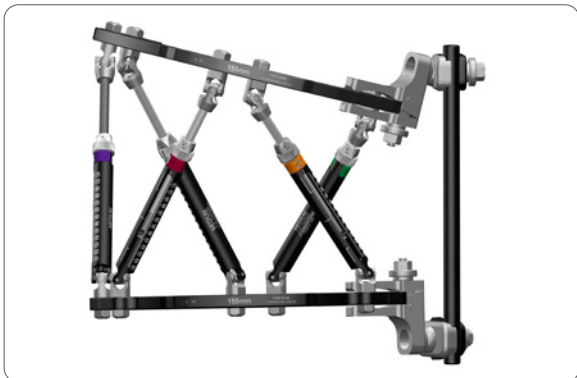

Remove the required Strut and replace with a new Strut. Tighten the Shoulder Bolts with the Torque Limiting Wrench.

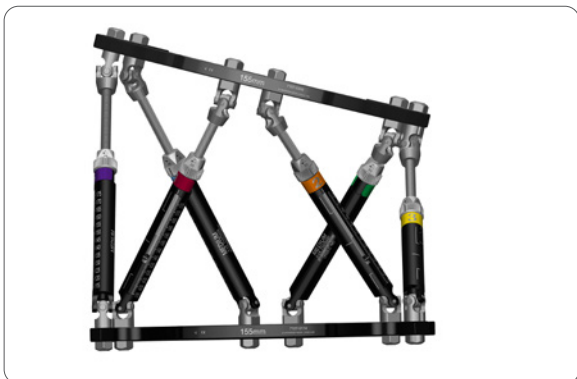

Remove the Frame Stabilizers.

Removal of TSF[◇]

All components can be loosened with a pair of 10mm x 13mm Wrenches (L202002 or 71075900).

Set Screw removal requires 3mm Hex Driver (112719).

Wires should be cut close to the skin and pulled through using Wire Cutters (71070344). Always pull Olive Wires from the side with the olive, indicated by the black lines.

Pins can be reversed with a Universal Chuck T-Handle Driver (71170183) or the HA Pin Driver (71050031). Advancing the HA Pin by one-quarter turn before reversing may help to remove the Pin.

All External Fixation components are single use and should be disposed of in line with local biohazardous waste policy.

Tray Layout

Instrument Tray

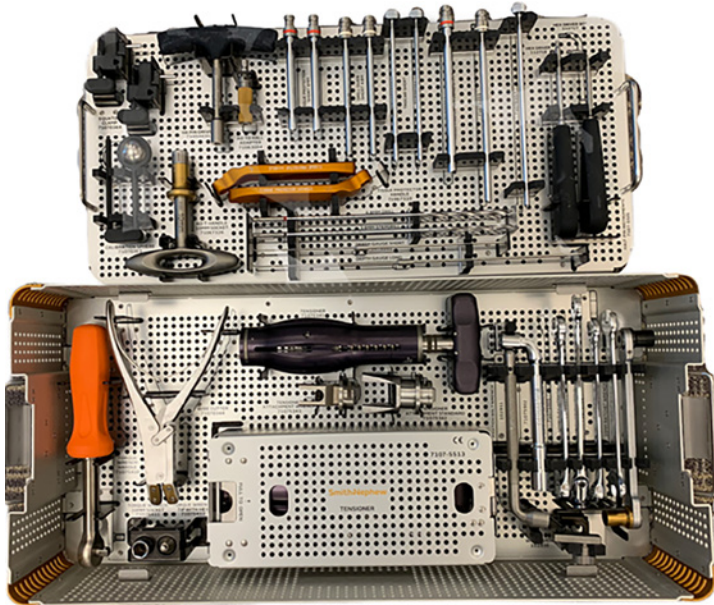

- Drill Guides, Handles, Screwdrivers, Tensioner and Wrenches
- One Tensioner is standard, with space for second one
- Alternatively, second Tensioner can be housed in its own caddy and wrapped separately
- Drills are supplied Sterile

Reference	Description	Qty
71075500	SMART TSF Instrument Case	1
71075501	SMART TSF Instrument Case Lid	1
71075505	Half Pin Instrument Case	1
Bottom Tray		
71075410	Torque Wrench Handle	1
71075411	Torque Wrench Hex Tip	1
71075412	Torque Wrench Socket	1
71070344	Wire Cutter	1
71075341	Wire Tensioner	2
71075342	Tensioner Jaw Attachment	2
71075343	Tensioner Wrench Attachment	2
71075513	Tensioner Caddy	1
102911	Fixation Bolt Wrench	1
102910	Slotted Hex Wrench	1
71075902	Tubular Angulated Wrench	1
71075905	Combination Wrench 10mm	1
71075900	10mm x 13mm Wrench	2
71075367	Ratchet Wrench	1
102930	Wire Guide Assembly	1

Top Tray		
71070363	Calibration Sphere	1
71070364	Equator Clamp	2
71067326	T-Handle	1
71050031	HA Pin T-Handle	1
71063004	AO to Hall Adapter	1
71067310	Tissue Protector Handle	2
71070352	Tissue Protector - Short	2
71070353	Tissue Protector - Long	1
71070354	Drill Tissue Protector - Short	2
71070355	Drill Tissue Protector - Long	1
71070356	Trocar Short	2
71070357	Trocar Long	1
112717	HEX-FIX 90° Hexdriver	1
112719	HEX-FIX Straight Hexdriver	1
71070361	Depth Gauge Short	1
71070362	Depth Gauge Long	1

Hardware Tray

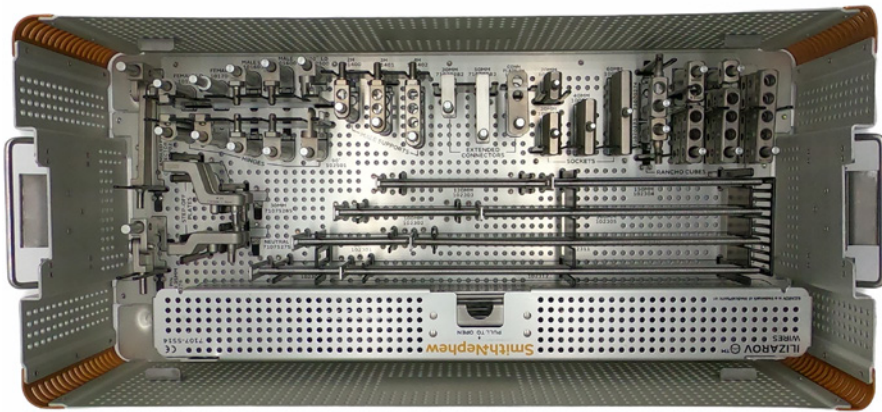
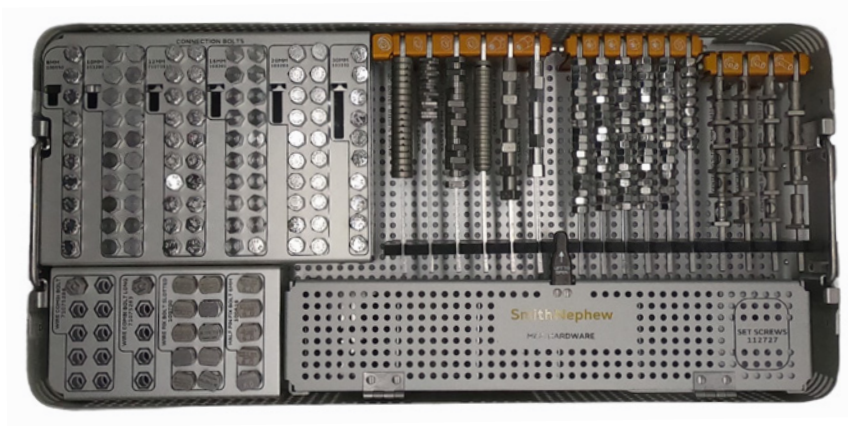

- Rods, Posts, Hinges, Nuts, Bolts, Washers, Ranchos and Plates
- Two level tray, can be split and housed as two Trays by using Hardware Tray Half Size
- Measure for Bolts on Bolt caddy.
- Stair-step configuration to match Bolt length
- Rack system for cannulated components. Silicon Stopper keeps them in place
- Utility spaces for any optional add-ons required by user
- Wire Caddy houses up to 48 Wires of any design to be loaded

Reference	Description	Qty
71075502	SMART TSF Hardware Case	1
71075501	SMART TSF Hardware Case Lid	1
71075504	SMART TSF Hardware Upper Tray	1
71075503	SMART TSF Hardware Half Tray (option)	1
71075511	SMART TSF Hardware Half Tray Lid (option)	1
Bottom Tray		
71070278	Angled Pin Connector 85mm	2
71070276	Angled Pin Connector 35mm	2
71075275	Step Off Plate Neutral	2
71075285	Step Off Plate 30mm	2
101702	Low Profile Female Hinge	4
101700	Female Hinge	4
101602	Low Profile Male Hinge	4
101600	Male Hinge	4
102500	Hinge 90° Low Profile	2
102501	Hinge 90°	2
101400	Male Support 2 Holes	2
101401	Male Support 3 Holes	2
101402	Male Support 4 Holes	2
71070282	Extended Connector Short 30mm	2
71070283	Extended Connector Long 50mm	2
101800	Short Connection Plate 3H 45mm	2
100900	Threaded Socket 20 mm	4
100910	Threaded Socket 30 mm	4
100901	Threaded Socket 40 mm	4
100911	Threaded Socket 60 mm	4
71070273	Rancho Cube with Post 1H	2
71070274	Rancho Cube with Post 2H	2
103452	Rancho Cube 2H	2
103453	Rancho Cube 3H	4
103451	Rancho Cube 1H	2
103454	Rancho Cube 4H	4
103455	Rancho Cube 5H	4
102300	60mm Threaded Rod	5
102301	Threaded Rod 80mm	5
102302	Threaded Rod 100mm	5
102303	Threaded Rod 120mm	5
102304	Threaded Rod 150mm	5
102305	Threaded Rod 200mm	5
102311	Threaded Rod 250mm	5
102312	Threaded Rod 300mm	5
71075514	Wire Caddy (fill with preferred selection of Wires)	1
102102	Wire 1.8mm Bayonet Tip Smooth	12
102107	Wire 1.8mm Bayonet Tip Olive	12

Top Tray - Wire Fixation Bolt Caddy

71075284	Wire Combi Bolt	10
71075283	Wire Combi Bolt Long	5
100700	Slotted Wire Fixation Bolt	10
100616	Half Pin Fixation Bolt 6mm	5

Top Tray - Bolt Caddy

100550	Bolt 8mm	10
103200	Bolt 10mm	20
71070515	Bolt 12mm	20
103201	Bolt 16mm	20
103203	Bolt 20mm	20
103202	Bolt 30mm	10

Top Tray - Skewer Rack

102600	Washer Slotted 4 x 14mm	20
102706	Washer 2.0mm Fixation Bolt	20
102707	Washer 4.0mm Fixation Bolt	20
201700	Conical Washer Couple	15
103302	DC Counter	6
71070285	Russian Long Nut	5
103300	Nut 10mm	100
103301	Nylon Nut 10mm	10
103405	Centering Sleeve 5mm	6
103406	Centering Sleeve 6mm	12
71070272	Centering Sleeve 6mm Long	4
71075521	Silicon Stopper for Hardware Tray (pack of 8)	2

Misc Hardware Caddy - utility space for extra components

112727	Set Screw	10
--------	-----------	----

SMART TSF[®] Rings Case



- Ring Case houses two Ring Modules
- Ring Module houses 8 Rings up to 205mm
- Ring Module should be pulled out straight (do not pull up)
- Ring Module can be stored on its own, with Lid
- Labels slide into window on Module. Blank labels supplied, for custom-labeling.
- Bumpers are optional to prevent small Rings from sliding side-to-side

Reference	Description	Qty
71075506	SMART TSF Ring Case - houses 2 Ring Modules	2
71075507	SMART TSF Ring Module	5
71075508	SMART TSF Ring Module Lid	1
71075522	Silicon Bumper for Ring Module (pk8)	1
71075520	SMART TSF Labels for Ring Module	1
71075112	SMART TSF Full Ring 105mm	2
71075113	SMART TSF Full Ring 130mm	2
71075114	SMART TSF Full Ring 155mm	2
71075115	SMART TSF Full Ring 180mm	2
71075116	SMART TSF Full Ring 205mm	2
71075117	SMART TSF Full Ring 230mm	0
71075123	SMART TSF Half Ring 130mm	2
71075124	SMART TSF Half Ring 155mm	2
71075125	SMART TSF Half Ring 180mm	2
71075126	SMART TSF Half Ring 205mm	2
71075132	SMART TSF 2/3 Ring 105mm	2

Reference	Description	Qty
71075133	SMART TSF 2/3 Ring 130mm	2
71075306	SMART TSF 2/3 Ring 155mm	2
71075307	SMART TSF 2/3 Ring 180mm	2
71075308	SMART TSF 2/3 Ring 205mm	2
71075302	SMART TSF U Ring 105mm	2
71075303	SMART TSF U Ring 130mm	2
71075304	SMART TSF U Ring 155mm	2
71075305	SMART TSF U Ring 180mm	2
71075509	Foot Module	1
71075511	Lid for Struts / Foot / Inner Hardware	1
71075144	SMART TSF Foot Ring 155mm Long	1
71075145	SMART TSF Foot Ring 180mm Long	1
71075154	SMART TSF Foot Ring 155mm Short	1
71075155	SMART TSF Foot Ring 180mm Short	1

Foot Tray

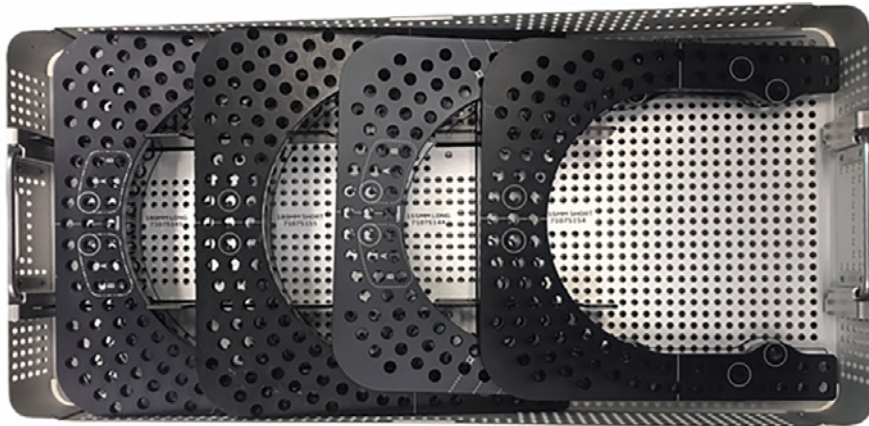

One of each 155mm & 180mm Short and Long

Strut Tray

NOTE The Beacon Mount is housed on the Strut Trays.

Standard Strut Tray

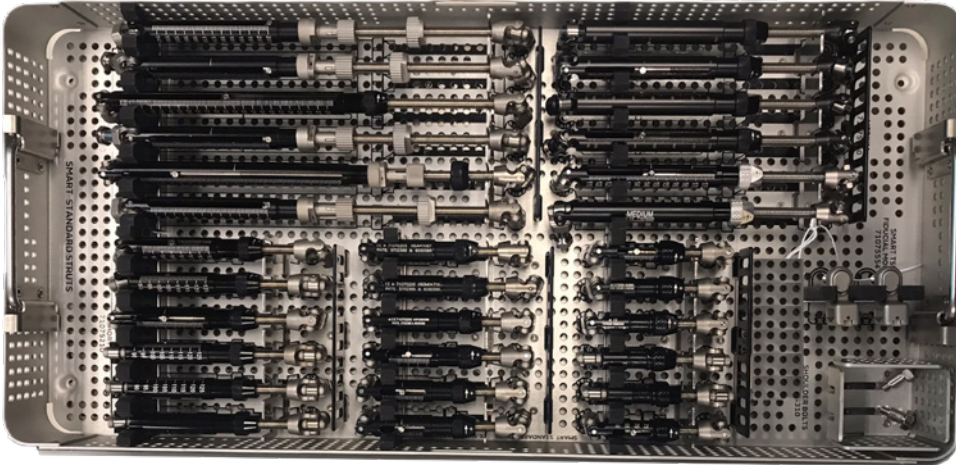

SMART FX Strut Tray

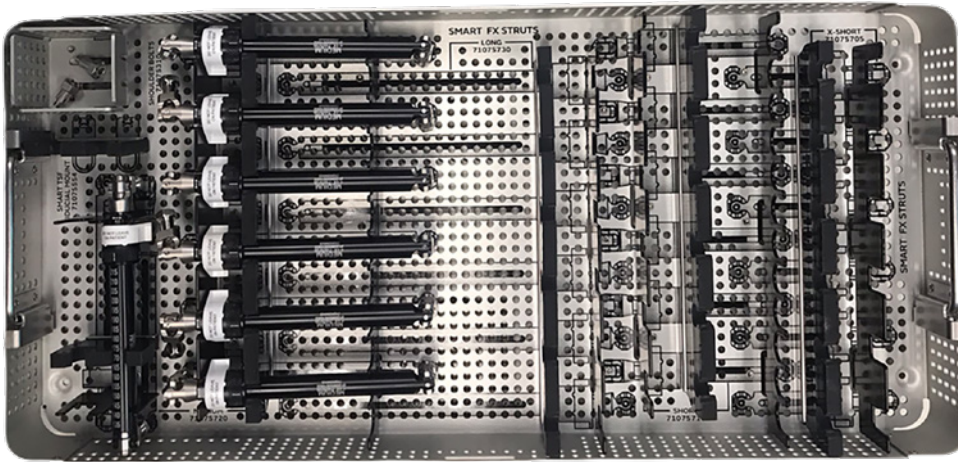

FAST FX[®] Strut Tray

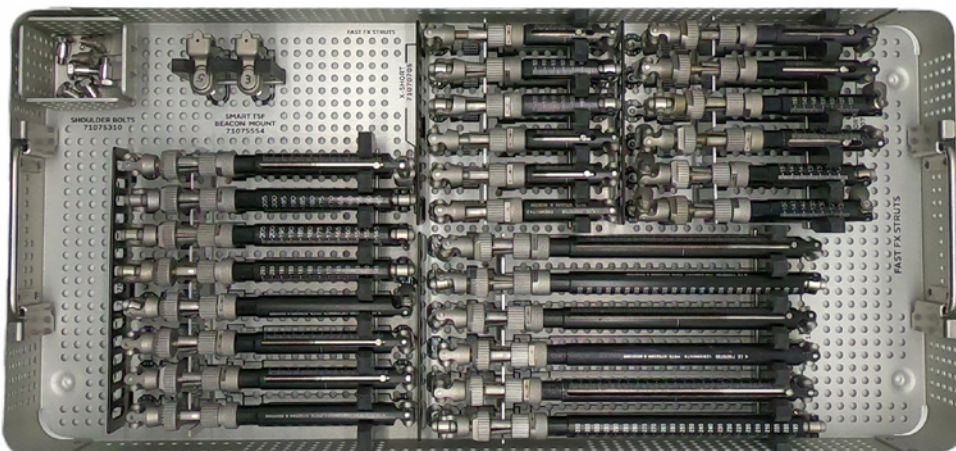

Reference	Description	Qty
71075512	SMART STANDARD Strut Tray	
71075200	SMART STANDARD Strut XX-Short	6
71075205	SMART STANDARD Strut X-Short	6
71075210	SMART STANDARD Strut Short	6
71075220	SMART STANDARD Strut Medium	6
71075230	SMART STANDARD Strut Long	6
71075510	SMART FX Strut Tray	
71075705	SMART FX Strut X-Short	6
71075710	SMART FX Strut Short	6
71075720	SMART FX Strut Medium	8
71075730	SMART FX Strut Long	6
71075020	Acute Adjustment Clip	6
71075516	FAST FX[®] Tray	
71070705	FAST FX Strut X-Short	6
71070710	FAST FX Strut Short	6
71070720	FAST FX Strut Medium	8
71070730	FAST FX Strut Long	6
71075554	SMART TSF [®] Beacon Mount	2
71075310	SMART Strut Shoulder Bolt	6
71075511	SMART TSF Strut Tray Lid	1

Clinic Set

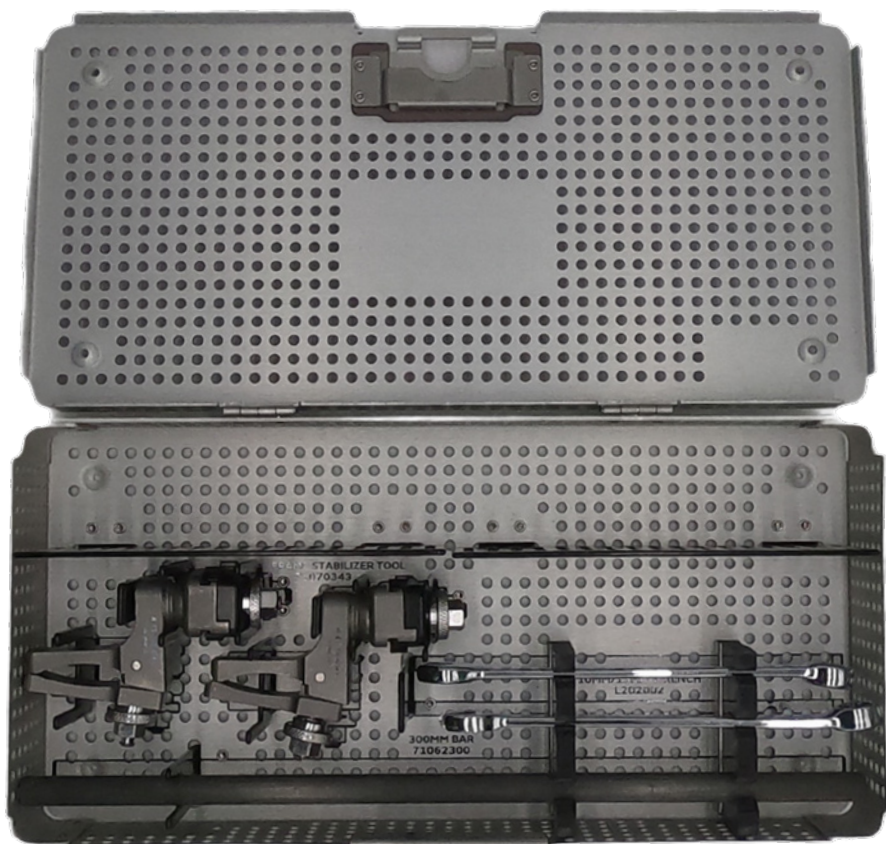

- Designed to support hardware adjustments in the Out-Patients Clinic
- 300mm Bar and two Frame Stabilizer Tools are used to stabilize the TSF[®] while a Strut is swapped out, or Dynamization applied.
- Two 10 x 13mm Wrenches included
- Utility space allows storage of miscellaneous components
- The set can be sterilized for use in the OR if required

Reference	Description	Qty
71075515	Clinic Set Tray	1
L202002	10mm x 13mm Wrench	2
71062300	300mm JetX Bar	1
71070343	Frame Stabilizer Tool	2

Catalog Information

Extended HA Coated Pins Sterile

Reference	Description	Qty
71074510	Extended HA Pin 4.5mm 10mm x 150mm	2
71074515	Extended HA Pin 4.5mm 15mm x 150mm	2
71074520	Extended HA Pin 4.5mm 20mm x 150mm	2
71074525	Extended HA Pin 4.5mm 25mm x 150mm	2
71074530	Extended HA Pin 4.5mm 30mm x 150mm	2
71074535	Extended HA Pin 4.5mm 35mm x 150mm	2
71074540	Extended HA Pin 4.5mm 40mm x 150mm	2
71074550	Extended HA Pin 4.5mm 50mm x 150mm	2
71076515	Extended HA Pin 6mm 15mm x 150mm	2
71076520	Extended HA Pin 6mm 20mm x 150mm	2
71076525	Extended HA Pin 6mm 25mm x 150mm	2
71076530	Extended HA Pin 6mm 30mm x 150mm	2
71076535	Extended HA Pin 6mm 35mm x 150mm	2
71076540	Extended HA Pin 6mm 40mm x 150mm	2
71076545	Extended HA Pin 6mm 45mm x 150mm	2
71076550	Extended HA Pin 6mm 50mm x 150mm	2
71076555	Extended HA Pin 6mm 55mm x 150mm	2
71076560	Extended HA Pin 6mm 60mm x 150mm	2
71076565	Extended HA Pin 6mm 65mm x 150mm	2
71076570	Extended HA Pin 6mm 70mm x 150mm	2
71076015	Extended HA Pin 6mm 15mm x 200mm	2
71076020	Extended HA Pin 6mm 20mm x 200mm	2
71076025	Extended HA Pin 6mm 25mm x 200mm	2
71076030	Extended HA Pin 6mm 30mm x 200mm	2
71076035	Extended HA Pin 6mm 35mm x 200mm	2
71076040	Extended HA Pin 6mm 40mm x 200mm	2
71076045	Extended HA Pin 6mm 45mm x 200mm	2
71076050	Extended HA Pin 6mm 50mm x 200mm	2
71076055	Extended HA Pin 6mm 55mm x 200mm	2
71076060	Extended HA Pin 6mm 60mm x 200mm	2
71076065	Extended HA Pin 6mm 65mm x 200mm	2
71076070	Extended HA Pin 6mm 70mm x 200mm	2
71076080	Extended HA Pin 6mm 80mm x 200mm	2
71076090	Extended HA Pin 6mm 90mm x 200mm	2

Drill for HA Pins

Reference	Description	Qty
71070345	3.8mm Drill Short for 4.5mm Pins	2
71070348	3.8mm Drill Long for 3.5mm Pins	2
71070346	4.8mm Drill Short for 6mm Pins	2
71070349	4.8mm Drill Long for 6mm Pins	2

SMART TSF[®] Sterile Accessories

Reference	Description	Pk Qty
71075050	SMART STD ID Band Kit	1
71075040	SMART FX ID Band Kit	1
71075315	Dynamization Kit - 6 Bolts and 6 Washers	6
71075316	Dynamization Washer	4
71078550	Coverion Clamp	2
71070290	Half Pin Cap 6mm (Orange)	6
71075295	Wire / Pin Stopper	6

SMART TSF Beacon

Reference	Description	Qty
71075555	SMART TSF Beacon*	1

*The Beacon is supplied and housed in a dedicated carry-case



See TSF[®] and ILIZAROV[™] Hardware Pocket Guide 29781 for a full list of circular fixation components.

Appendix

Reference Parameters on Hardware

The SMART TSF[®] Beacon is the most accurate method for calibrating X-ray images as it minimizes the error of parallax. If the Beacon is not available, a calibration sphere can be used, or reference dimensions on hardware such as the inner diameter of a Ring or Rancho Cubes. When scaling with known dimensions of hardware, accuracy will be improved by measuring large components. If these calibration strategies are used, then attention should be paid to measuring them in the same plane as the bone.

Size of Ranchos*

1H	15.75mm
2H	28.45mm
3H	41.15mm
4H	53.85mm
5H	66.54mm
Hole-to-hole distance 12.7mm	

Angles between holes on inner radius of Ring*

105mm	12°
130mm	10°
155mm	8.6°
180mm	7.5°
205mm	6.7°
230mm	6°
255mm	5.5°
275mm	5°
300mm	4.6°

*Measurements provided are nominal values within tolerated ranges for manufacturing specifications

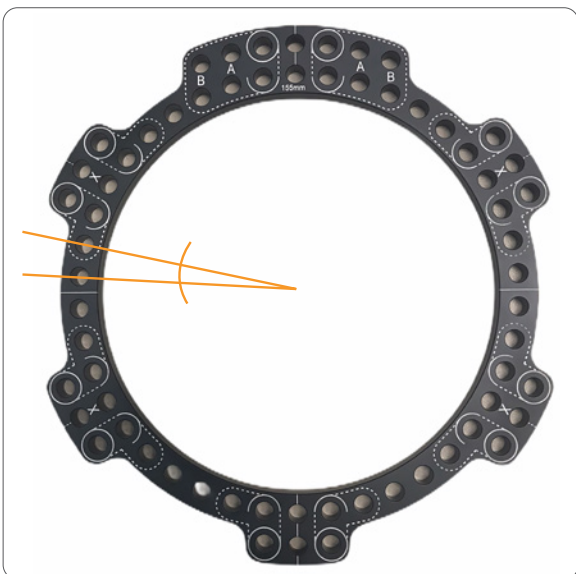

Struts Reference*

Measured deformity	Struts to lengthen	Struts to shorten
Left limb adjustments		
Medial translation	#2, 5	#1, 4
Lateral translation	1, 4	2, 5
Posterior translation	3, 6	1, 2, 4, 5
Anterior translation	1, 2, 4, 5	3, 6
Varus	6 (1, 5)	3 (2, 4)
Valgus	3 (2, 4)	6 (1, 5)
Apex Anterior	4, 5	1, 2
Apex posterior	1, 2	4, 5
External rotation	1, 3, 5	2, 4, 6
Internal rotation	2, 4, 6	1, 3, 5
Short limb	All struts	NA
Right limb adjustments		
Medial translation	1, 4	2,5
Lateral translation	2, 5	1, 4
Posterior translation	3, 6	1, 2, 4, 5
Anterior translation	1, 2, 4, 5	3, 6
Varus	3 (2, 4)	6 (1, 5)
Valgus	6 (1. 5)	3 (2, 4)
Apex Anterior	4, 5	1, 2
Apex posterior	1, 2	4, 5
External rotation	2, 4, 6	1, 3, 5
Internal rotation	1, 3, 5	2, 4, 6
Limb-lengthening	All struts	NA

*Assumes proximal ring reference and no rotary frame offset.

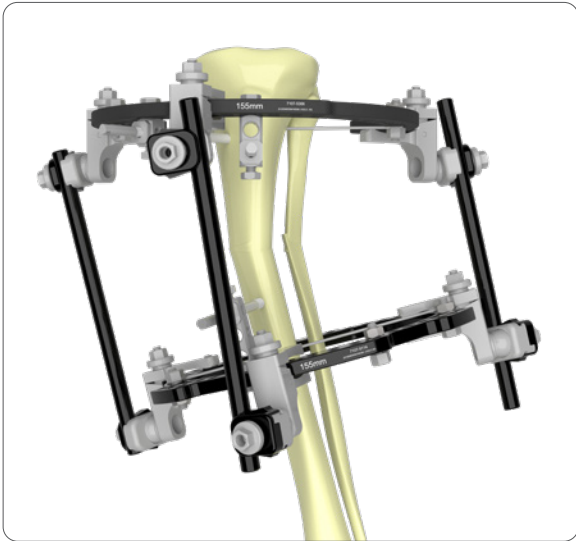

MR Safety Information

TSF[®] is MR Unsafe

TSF Struts and Threaded Rods are MR Unsafe, and these are an essential part of all TSF constructs. If a patient requires an MRI while TSF is in place, the Struts and Threaded Rods can be temporarily replaced by 6 Frame Stabilizer Tools and 3 Carbon Fiber Bars.

MR Conditionality is subject to the following parameters.

- The external fixator must remain outside of the MRI scanner bore.
- The patient must weigh at least 120 pounds.
- All struts must be removed. A maximum of two rings should be incorporated in the TSF. The rings of the TSF must be connected by carbon fiber rods using a maximum of 6 frame stabilizer tools.
- Static magnetic field of 1.5-Tesla (1.5 T) or 3-Tesla (3 T).
- Maximum spatial field gradient of 2,127 G/cm (21.3 T/m).
- Whole body averaged specific absorption rate (SAR) of 2.0 W/kg.
- The above SAR restrictions refer to whole body RF transmit coil using a circularly polarized transmit mode.

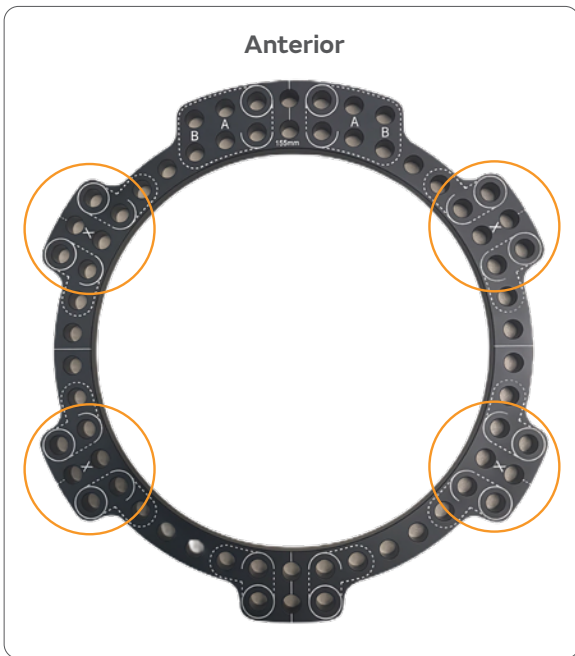

Beacon Mount Placement on classic TSF™ Rings

The original TSF Rings can still be used and are compatible with all features of SMART TSF hardware and software.

The only difference is absence of the markings shown here. Use this as a reference when applying original TSF Rings

Dashed lines indicate where Custom Strut Mount is an option

'X' indicates where the SMART TSF Beacon can be mounted assuming 0° Rotary Frame Offset

The central holes of the 7-hole tab and the opposing 3-hole tab are also options for Beacon mounting locations, if Rotary Frame Offset is present. The objective is to attach the Beacon to a tab that is not in the true AP or true Lateral position.



Beacon Mount Placement on classic TSF[®] Rings *continued*

The original TSF Rings can still be used and are compatible with all features of SMART TSF hardware and software.

The only difference is absence of the markings shown here. Use this as a reference when applying original TSF Rings.

Dashed lines indicate where Custom Strut Mount is an option

'X' indicates where the SMART TSF Beacon can be mounted.

The Beacon should not be mounted in the true AP or true lateral.



Products may not be available in all markets because product availability is subject to the regulatory and/or medical practices in individual markets. Please contact your Smith+Nephew representative or distributor if you have questions about the availability of Smith+Nephew products in your area.



Smith & Nephew, Inc.
1450 Brooks Road
Memphis, TN 38116
USA

www.smith-nephew.com

°Trademark of Smith+Nephew.
All trademarks acknowledged.
©2023 Smith+Nephew. All rights reserved.
30474 V3 71081187 REV 05/23

ILIZAROV is a Trademark of MedicalPlastic srl.

References

1. The Original ILIZAROV System General Surgical Technique Brochure; 7108-0238; MedicalPlastic 1998.
2. ILIZAROV GA. The Tension-Stress Effect on the Genesis and Growth of Tissues; USSR Academy of Sciences and the Kurgan All-Union Center for Restorative Traumatology and Orthopaedics, Kurgan, 1998.
3. Rampurada A, Madan S, Tadross T. Treatment of complex tibial plateau and distal tibial fractures with Taylor Spatial Frame: experience in a district general hospital. *Eur J Orthop Surg Traumatol.* 2008;18:521-524.
4. Ashfaq K, Fragomen AT, Nguyen TJ, Rozbruch SR. Correction of Proximal Tibia Varus with External Fixation. *J Knee Surg.* 2012; 25:375-384.
5. Elbatrawy Y, Fayed M. Deformity Correction With an External Fixator : Ease of Use and Accuracy? *Orthopedics.* 2009;32(2):82.
6. Sala F, Thabet AM, Castelli F, et al. Bone Transport for Postinfectious Segmental Tibial Bone Defects With a Combined ILIZAROV/Taylor Spatial Frame Technique. *J Orthop Trauma.* 2011;25:162-168.
7. Feldman DS, Shin SS, Madan S, Koval KJ. Correction of Tibial Malunion and Nonunion With Six-Axis Analysis Deformity Correction Using the Taylor Spatial Frame; *J Orthop Trauma.* 2003;17:549-554.
8. Dammerer D, Kirschbichler K, Donnan L, Kaufmann G, Krismer M, Biedermann R. Clinical value of the Taylor Spatial Frame: a comparison with the Ilizarov and Orthofix fixators. *J Child Orthop.* 2011;5:343-349.
9. Paloski, M; Taylor BC, Iobst, C; Pugh KJ. Pediatric and Adolescent Applications of the Taylor Spatial Frame *Healio.* 2012; 35(6):518-527.