

Surgical Technique
Universal Femoral Sizer for
ANTHEM PS
ANTHEM CR

 smith&nephew
ANTHEM[®]
Total Knee System



In consultation with:

Professor T.K. Kim – Seoul, South Korea

Professor D. Saris – Utrecht, Netherlands

Professor R. Tözün – Istanbul, Turkey

Professor Y. Zhou – Beijing, China

Professor A. Belooshi – Dubai, U.A.E.

Doctor M. Wadhwa – Chandigarh, India

Doctor R. McLennan-Smith – Durban, South Africa

Doctor J. Duboy - Santiago, Chile

ANTHEM[◊] PS and ANTHEM CR Total Knee System

Contents

Introduction	2
Preoperative planning	3
Femoral preparation	4
Tibial preparation - GENESIS [◊] II tibia jig	7
Femoral positioning and sizing	11
A/P and chamfer resection	15
Component trialling	17
Tibial keel preparation	20
Resurfacing patellar preparation	22
Implantation and closure	25
Tibial preparation - ORTHOMATCH [◊] Polymer tibia jig	28
Component trialling - Cruciate Retaining resection	32
Implant Compatibilities ANTHEM CR	36
Implant Compatibilities ANTHEM PS	37

Introduction

The ANTHEM® PS and the ANTHEM CR Total Knee System have been designed to offer orthopaedic surgeons solutions to address a range of intraoperative situations. Proper implant function is dependant on an extensive and accurate surgical technique. The ORTHOMATCH® Universal Instrumentation system is designed to be used with ANTHEM to provide an easy to use system that facilitates accurate and reproducible surgical outcome.

The system is designed to accommodate either a minimally invasive or standard surgical incision and exposure. While it is the designers' objective to develop accurate, easy-to-use instrumentation, each surgeon must evaluate the appropriateness of the following technique based on his or her medical training, experience and the specific patient clinical evaluation.

The general principles of good patient selection and sound surgical judgment apply to the total knee procedure. Preoperative planning and meticulous surgical technique are essential to achieve optimum results. Considerations of anatomic loading, soft-tissue condition, and component placement are critical to minimize a variety of postoperative complications.

Disclaimer

The following technique guide was prepared under the guidance of Professor T.K. Kim, Professor D. Saris, Professor R. Tözün, Professor Y. Zhou, Professor A. Belooshi, Doctor M. Wadhwa, Doctor R. McLennan-Smith and Doctor J. Duboy under close collaboration with each physician.

It contains a summary of medical techniques and opinions based upon their training and expertise in the field, along with their knowledge of Smith & Nephew products. It is provided for educational and informational purposes only. Smith & Nephew does not provide medical advice and it is not intended to serve as such.

It is the responsibility of the treating physician to determine and utilize the appropriate products and techniques according to their own clinical judgment for each of their patients. For more information on the products in this surgical technique, including indications for use, contraindications, effects, precautions and warnings, please consult the products' Instructions for Use (IFU).

This information contained herein may not be appropriate for all jurisdictions. In particular, the product(s) presented are not authorized for marketing in the United States.

Preoperative planning

On a full lower limb radiological view determine the angle between the anatomical and the mechanical axes. This measurement will be used intraoperatively to select the appropriate valgus angle so that correct limb alignment is restored. (Beware of misleading angles in knees with a flexion contracture or rotated lower extremities.)

Note: Many surgeons prefer to simply select a standard angle for the distal femoral cut (ie, 5°, 6° or 7°) based on the patient and surgical experience.

Recommended sawblade

Cutting thickness and blade thickness should be 0.053" or 1.35mm.

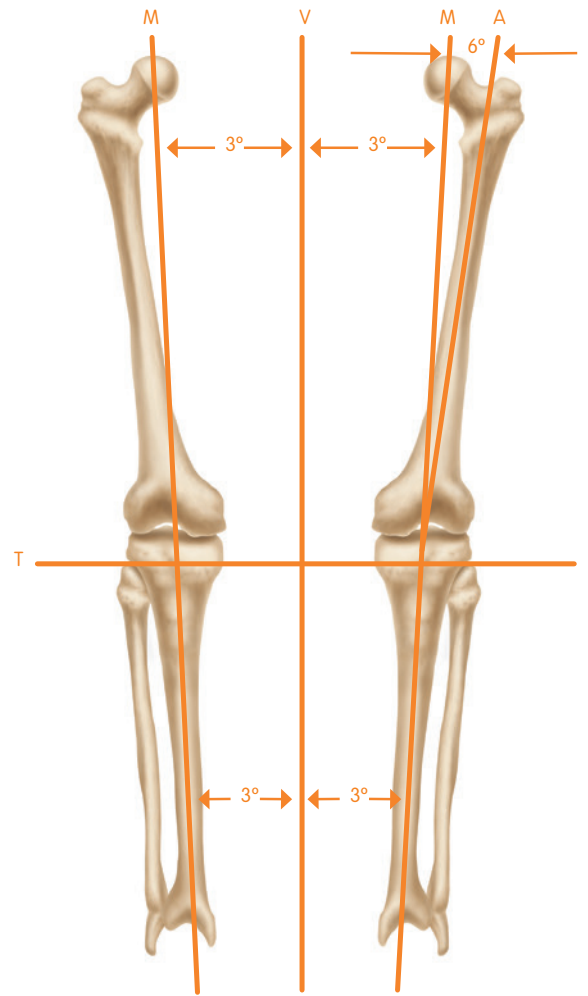

- M = Mechanical Axis
- A = Anatomical Axis
- T = Transverse Axis
- V = Vertical Axis

Femoral preparation

1. Open the femoral canal with the 9.5mm intramedullary drill. The drill has a 12mm step to open the entry point further (Figure 1).
2. Assemble the valgus alignment guide with the valgus bushing (5°, 6° or 7°) Right or Left mark facing upwards to match the correct side (hand) of the knee based on preoperative planning and assessment of valgus angle.
3. Slide the IM T-Handle rod through the valgus bushing and in to the femoral canal until the assembled valgus alignment guide touches at least one of the distal femoral condyles (Figure 2).
4. Connect the universal cutting block to the valgus alignment guide with the “F” mark facing upwards and allow the cutting block to sit in a neutral position within the trochlea. Turn the threaded knob clockwise to secure the universal cutting block to the valgus alignment guide assembly.
5. Use trocar pins to secure the distal femoral cutting block to the anterior femur through the two holes marked “0” (Figure 3).

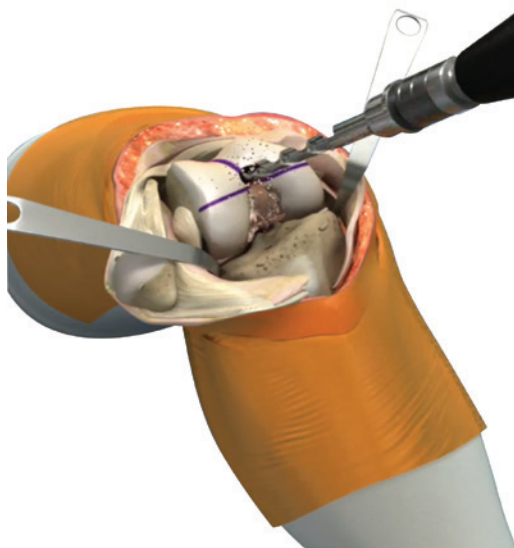

Figure 1

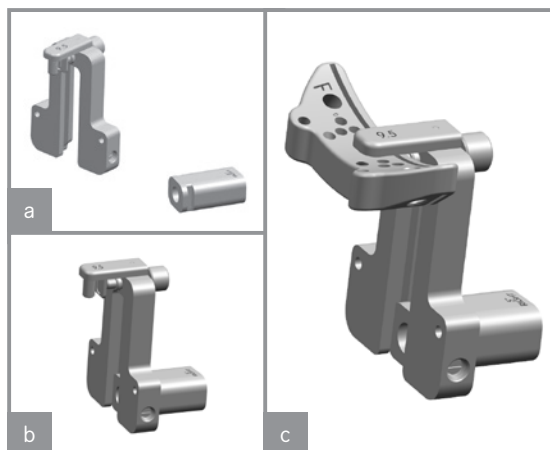

Figure 2

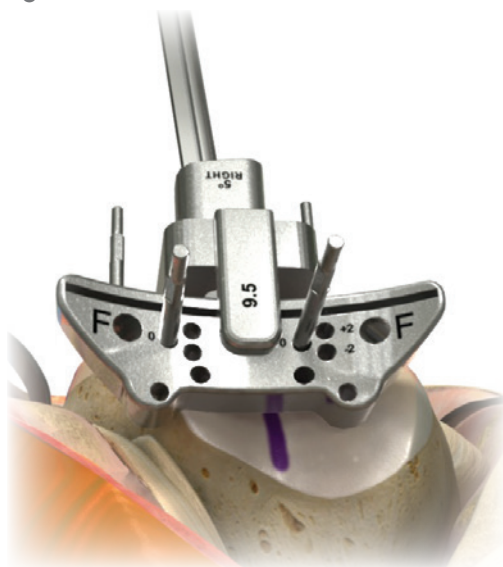

Figure 3

6. Once the universal cutting block is secured with pins, remove pins from the valgus alignment guide. Turn the threaded knob counterclockwise to release the universal cut block and slide valgus alignment guide anteriorly to fully remove it. Then remove the IM-handle and valgus bushing from the intramedullary canal.
7. Extend the knee fully and insert drop rod guide assembly in to the blade slot of the universal cutting block to check Hip Knee Mechanical Axis (HKA) before resection (Figure 4).



Figure 4

8. By sliding the resection check guide (angel wing) in to the blade slot of the universal cutting block assess the bone resection level before performing the resection. The universal cutting block pinned through the “0” holes will resect 9.5mm from the prominent condyle of the femur (Figure 5).
9. If additional bone removal is desired, for example in the case of a fixed flexion deformity, the universal cutting block can be shifted superiorly by removing it from the pins and reinserting it onto the “+2” pin holes. This will result in a 11.5mm distal resection (Figure 6).

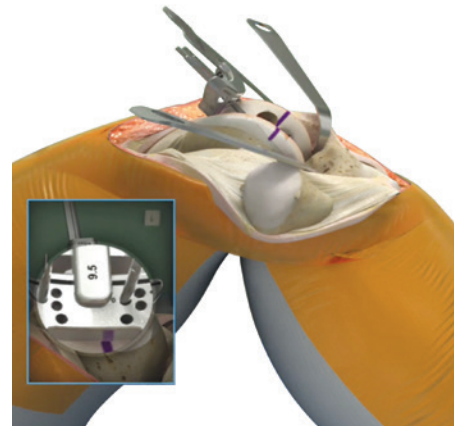

Figure 5



Figure 6

Femoral preparation *continued*

10. Once resection level and alignment are determined, insert a third pin into the angled pin hole to secure the universal cutting block in position. Resect the distal femur using an oscillating saw (Figure 7).

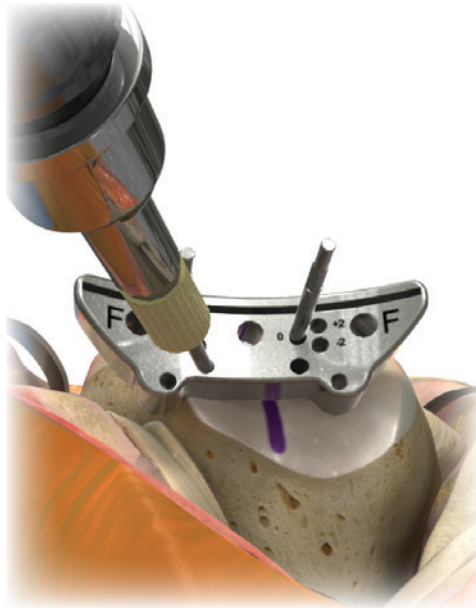

Figure 7

11. Once resection is complete then remove pins and the universal cutting block from the femoral bone and remove the cut bones from the distal condyles (Figure 8).

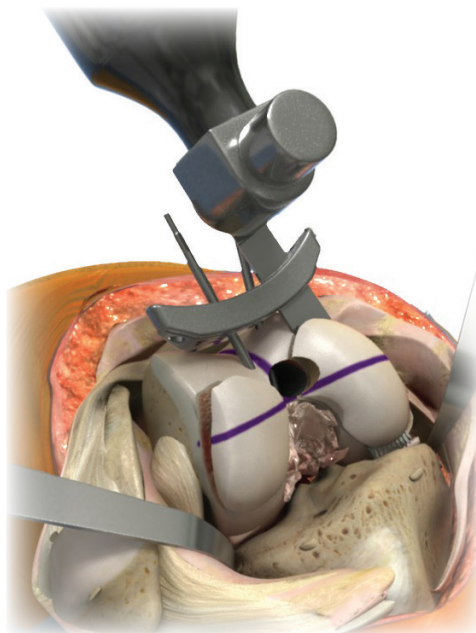

Figure 8

Tibial preparation

Note: If the ORTHOMATCH® Polymer tibia jig is used to perform the proximal tibia cut, please go to page 28. If you are using the GENESIS® II tibia jig please continue to Step 1 below.

The GENESIS® II Tibia Jig included in the ORTHOMATCH® set configuration utilizes an extramedullary guide with a spiked rod.

Extramedullary Tibial Alignment Instrument Assembly:

- Insert the ankle clamp into the distal end of the alignment tube and thread the locking pin into the ankle clamp (Figure 9).
- After the ankle clamp is moved into the proper position, lock into place with the gold knob.
- Choose the correct left or right tibial cutting block. Select the spiked fixation rod.



Figure 9

Spiked Fixation Rod Instrument Assembly:

- Place the spiked fixation rod through the central anterior hole in the tibial cutting guide; adjust the block and tighten the central knob to lock the block in position.
 - Introduce the spiked fixation rod into the proximal end of the alignment assembly and adjust and lock the cam on the assembly (Figure 10a).
- Place the arms of the extramedullary alignment clamp around the ankle, and adjust the distal M-L slide directly over the middle of the tibiotalar joint which is also approximated by the second ray of the foot proximal to the malleoli (Figure 10b). The cutting block on the proximal end of the assembly should be proximal to the tibial tubercle (Figure 10c).



Figure 10a

Figure 10b

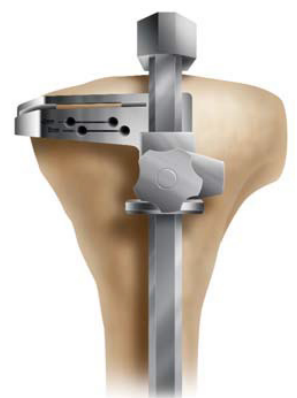

Figure 10c

Tibial preparation *continued*

2. Impact the longer spike of the spiked fixation rod into the proximal tibia (Figure 11).
3. Assess rotation of the alignment guide and slope of the cutting plane. The goal is to align the extramedullary alignment assembly rotationally so that it aligns over the medial third of the tibial tubercle and over the second toe (Figure 12a).
4. Rotational alignment is critical due to the 3° posterior sloped cut. The slope can be adjusted according to the patient's anatomy (Figure 12b). Impact the second spike to secure the assembly (Figure 12c).

Note: 3-5° of slope is built into the articular insert (depending on which insert is chosen) and 3° of slope is built into the tibial cutting block. A neutral or slightly sloped alignment should usually be chosen.

Tip: Neutral or minimally sloped alignment may be achieved by palpating the fibula followed by aligning the alignment guide parallel to the fibula. Tibial bowing and soft tissue bulk may make external tibial referencing unreliable.



Figure 11



Figure 12a



Figure 12b



Figure 12c

Tibial Resection

1. Attach the tibial stylus to the tibial cutting block by inserting the stylus foot into the cutting slot.
2. Lower the cutting block until the stylus touches the low point on the less affected side of the tibia (Figures 13a). The stylus can be adjusted for a 9, 11 or 13mm tibial resection by twisting the knob on top of the stylus.
3. Pin the tibial cutting block to the tibia by inserting pins first through the central holes; then the oblique hole.

Tip: Pinning through the central holes marked 0mm with smooth pins will allow the block to be moved +2mm should additional resection be required (Figure 13b).

Tip: A 9mm resection is recommended since 9mm of metal and plastic is the thinnest available component.

Tip: To do an extramedullary alignment check, place the extramedullary alignment rod through the tibial cutting block.



Figure 13a



Figure 13b

Tibial preparation *continued*

To remove the assembly:

For the extramedullary assembly with spiked rod, release the cam at the top of the alignment tube and using the slap hammer to remove the spiked fixation rod (Figure 14a) after loosening the thumbscrew.

4. Cut the tibia by first directing the blade in the posterior direction and then laterally (Figure 14b).
5. Check alignment and balance with spacer block and rod (Figures 14c & 14d). Balance ligaments in standard fashion.



Figure 14a

Figure 14b



Figure 14c

Figure 14d

Femoral positioning and sizing

The ORTHOMATCH® femoral sizing guide allows for external rotation to be set from 0-9° based on surgeon preference and patient anatomy. Rotational alignment may be checked by aligning the A/P axis (Whiteside's Line) with the vertical marks on the sizing guide or by ensuring that the "EPI" lines on the face of the guide are parallel with the epicondylar axis. Once rotation is set the guide can be locked by turning the quick connect handle.

The sizing guide can be used for either posterior referencing or anteriorly referencing by utilizing either the "Ant Ref" or "Post Ref" holes. These holes correlate with similar holes on the A/P resection blocks.

The femoral size is indicated on either side of the femoral housing of the sizer. In addition, the femoral stylus is marked with sizing correlating with the femoral flange length / anterior sawblade exit point.

Stylus marked to indicate anterior femoral flange length/sawblade exit point

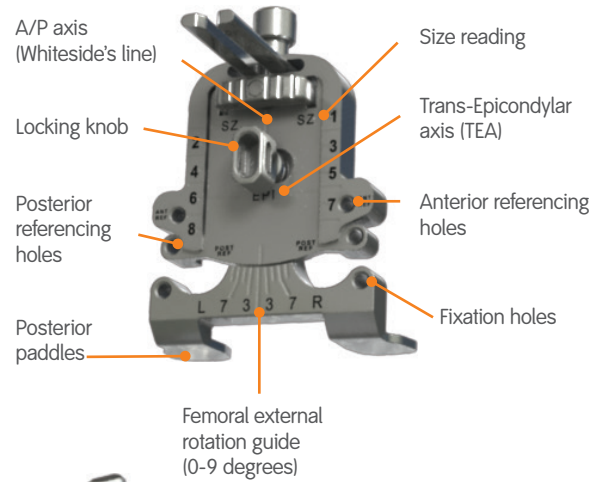

Quick connection handle attaches to sizing guide for application to resected distal femur

Femoral positioning and sizing *continued*

Sizing steps are as follows:

Optional: Mark the AP and epicondylar axis on the femur (Figure 15).

- a. Place sizing guide onto resected distal femur
- b. Pin guide through fixation holes to provide stability
- c. Select desired femoral external rotation 0-9°
- d. Note indicated size – if between sizes see surgical step 7 below for more detail
- e. Select Anterior or Posterior referencing
- f. Pin either anterior or posterior referencing holes with trocar pins
- g. Leave pins in place for femoral cutting block

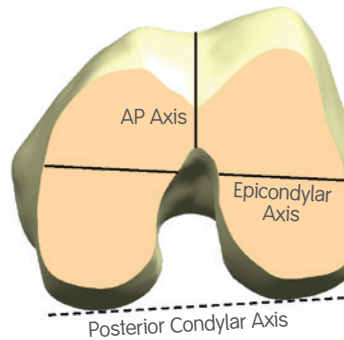

Figure 15

1. Place the Femoral Sizer Guide flush to the resected distal femur by using the quick connect handle to ensure both the posterior paddles of the Femoral Sizer Guide are in contact with the underside of the posterior condyles (Figure 16).

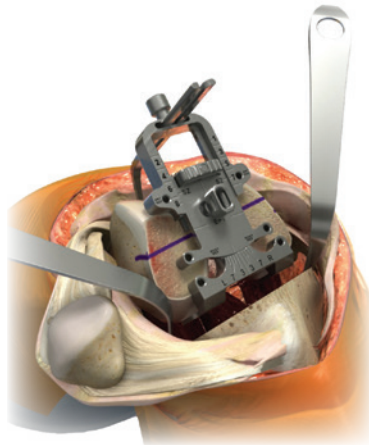

Figure 16

2. Secure the guide to the bone through the two pin holes located at the bottom of the sizing guide (Figure 16a).



Figure 16a

3. It is important to use the distal femoral anatomic landmarks (AP axis and Epicondylar Axis) of the knee to guide external rotation and to ensure optimized sizing, ligament balance and patella tracking.

This is commonly set at 3°. However, certain patient groups have higher external rotation of the femur, which correlates to a greater degree of tibia vara. In these patients more external rotation of the femoral component should be considered (Figure 16b).

Note: Ensure that the appropriate side is chosen when setting external rotation, ie, “L” for left and “R” for right

4. Once the desired external rotation is set, lock the sizing guide by rotating the central knob clockwise with the Quick Connect Handle.

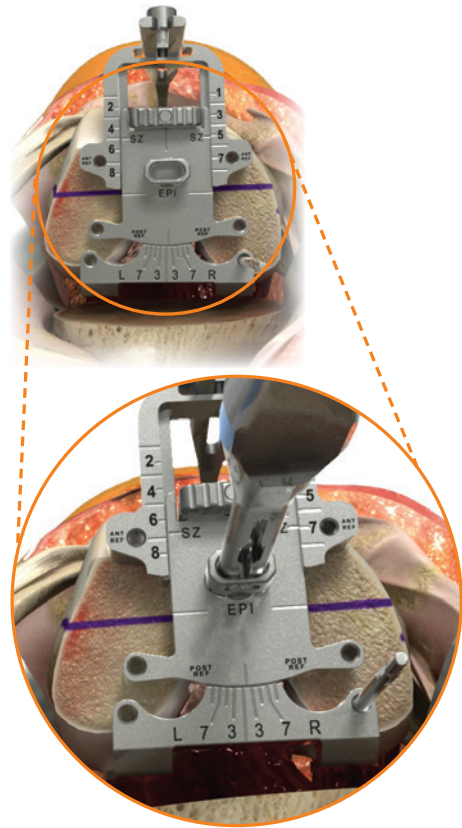

Figure 16b

5. In order to determine femoral size, position the stylus tip just lateral of the anterior trochlear sulcus and slide the femoral sizer housing down until the stylus touches the anterior cortex. The size is indicated against the laser marked “SZ” (Figure 16c).

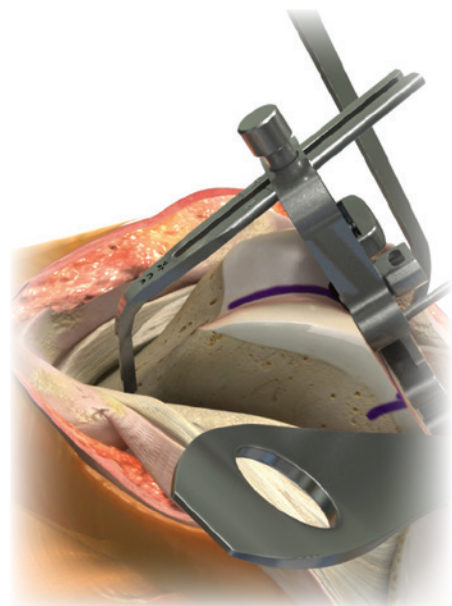

Figure 16c

Femoral positioning and sizing *continued*

- Slide the femoral stylus backward or forward so that the size indicated on the femoral stylus matches the femoral size indicated on the Femoral Sizer Guide. The point at which the femoral stylus contacts the bone marks the peak of the femoral anterior flange (Figure 16d).

Note: The indicator mark on the stylus should be aligned with the edge of the sizer closest to the femoral resection.

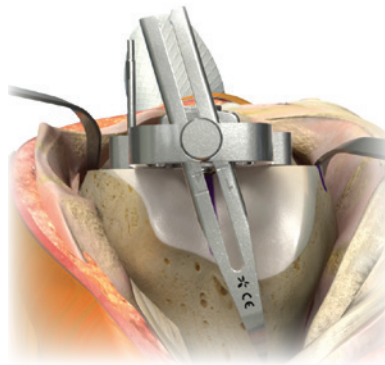

Figure 16d

- If between sizes, it is recommended to use the following protocol depending on preferred referencing technique.

Posterior referencing

Choose the next larger size (ie, upsize) to reduce the risk of anterior notching

Anterior referencing

Choose the next smaller size (ie, downsize) to avoid overstuffing the flexion space

Note: The average difference between sizes of the ANTHEM[®] femoral implant sizes is 3mm.

- Once implant size and external rotation are determined place two pins in the appropriate anterior OR posterior referencing pin holes (not both). Remove the Femoral sizing guide by sliding it off the secured trocar pins, leaving the pins in situ (Figure 16e and 16f).

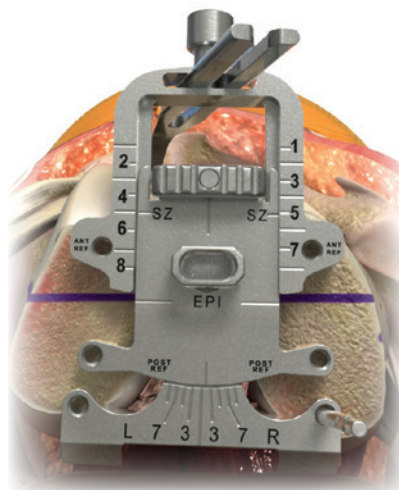

Figure 16e

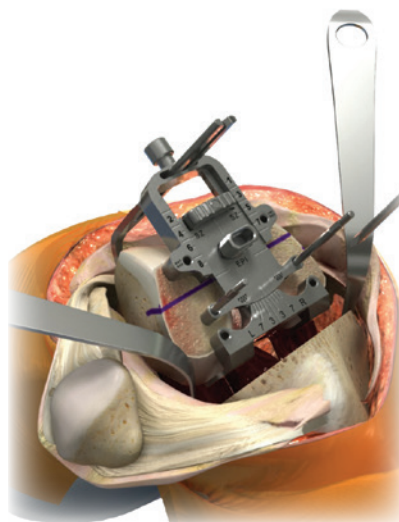

Figure 16f

A/P and chamfer resection

1. Select the appropriate size A/P resection block and place over the pins through the appropriate anterior or posterior referencing holes. Ensure that the cutting block is flush with the resected distal femur (Figure 17).
2. Prior to bone resection, insert the resection check (angel wing) into the anterior blade slot of the A/P resection block to check the plane of the resection and to avoid any chance for notching (Figure 17a).

Note: Component size can also be estimated by the M-L dimension of the cutting block at the condylar and junctional region. The cutting block M-L width corresponds to the standard size (not Narrow) ANTHEM[®] femoral component.



Figure 17

AP translations

Should any fine adjustment be required at this stage, then an option is to use the anterior OR posterior referencing translation blocks. These are designed to allow fine adjustment of the A/P position of the femoral cutting block.

To use the translation block remove the trocar pins, placing the spikes on the back of the block into the same location holes used for the A/P cutting block, and then re-drill pins in the new position. It is useful to mark the original pin track holes with a marking pen in order to properly identify the new holes.

Care must be taken when using these translation blocks as any translation of the cutting block may affect both the posterior flexion space and patello-femoral joint space.

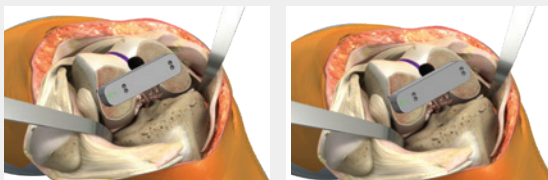

Anterior referencing block

Posterior referencing block

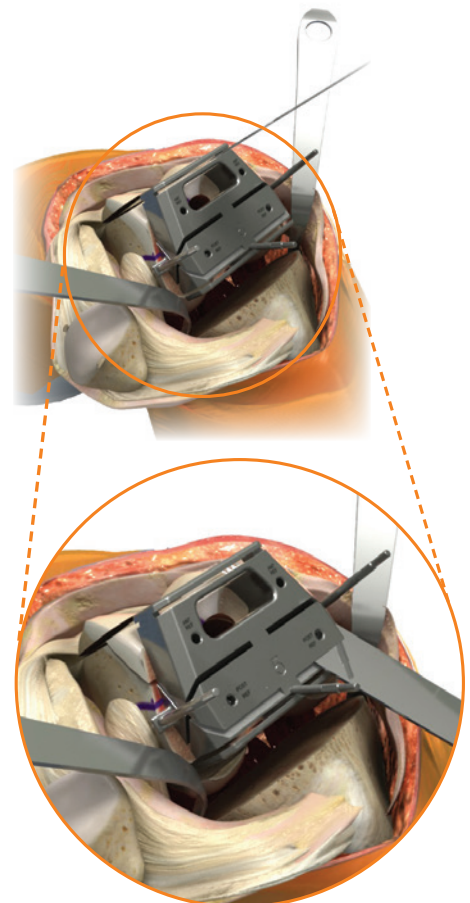

Figure 17a

3. In order to secure the block there are additional fixation holes medially and laterally as well as a central pin hole. Once secure remove the anterior or posterior referencing pins from the block.

A/P and chamfer resection *continued*

4. Complete the anterior, posterior and chamfer cuts with an oscillating saw. The block is designed to allow for angling of the sawblade during the cuts.

Note: To maintain block stability, the anterior chamfer cut should be completed last.

5. Once all resection cuts are complete, remove the A/P Resection Block and remaining pins from the bone.

6. Ensure the knee is flexed to 90 degrees to check flexion gap balance using the appropriate spacer block and rod. There should be 1-2mm of laxity laterally only. The aim is to have equal flexion and extension spaces (Figure 18, 18a, and 18b).

Note: The AP cutting blocks for size 7 and 8 will resect 11.5mm of bone for the posterior cut. This is 2mm more than the other sizes. When checking the flexion gap it will be necessary to add the 2mm shim on the spacer block. The extension gap will not require the shim. When trialing no additional concessions are needed. The implant trials dimensionally represent the implants.

Note: Surgical tips to achieve optimal flexion:

- **Avoid** posterior impingement of femoral component by ensuring adequate size and correct posterior condylar offset
- **For CR Implants:** Keep the PCL intact.
For PS Implants: Excise the entire PCL attachment from the femoral intercondylar notch with either a cautery or scalpel as the PCL has been shown to constrain flexion assessment
- **Use** a curved/offset osteotome to remove any posterior osteophytes
- **Correctly** balance the flexion gap
- **Prevent** overhang of the femoral and tibial components
- **Ensure** correct tibial slope
- **Beware** of the neurovascular structures at the posterior aspect of the knee joint

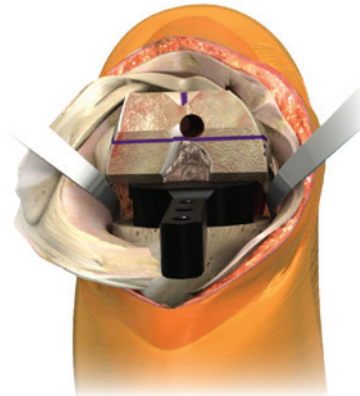

Figure 18



Figure 18a

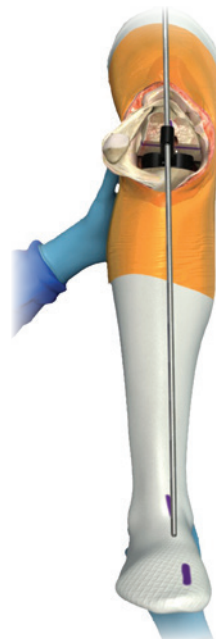

Figure 18b

Component trialling

1. Flex the knee to 90° and insert the appropriate sized femoral trial using the femoral trial impactor.

Note: To avoid the trial slipping into flexion, the trial femoral impactor can also be used as a notch Impactor by rotating it 180 degrees and impacting the anterior femoral notch area (Figure 19).

2. The femoral trial should be both fully seated and flush with the lateral cortex avoiding excessive overhang on either side of the bone. If overhang is present a narrow implant can be selected, indicated by the laser markings either side of the trial.

Note: It is important also to assess the fit of the trial in the trochlea and trochlea junction area to avoid any overhang.

Note: The ANTHEM Femoral Trials can be used to trial for both ANTHEM Posterior Stabilized (PS) and Cruciate Retaining (CR) implants. For PS implants, proceed to step 3. For CR implants, proceed to page 28, step 1 (Component Trialing - Cruciate Retaining resection).

3. Secure the selected femoral trial to the bone using two short headed pins in the anterior flange (Figure 20).
4. The ANTHEM® femoral trials are available in either metal or high grade polymer. If using Metal Trials, insert the appropriate sized housing collet (size 1-2 or 3-8) to the trial femoral component by sliding the housing collet from anterior to posterior in the provided slot.

- 4a. If polymer femoral trials are used then attach the collet guide housing first on to the distal surface of the femoral trial by screwing in the distal screws into the femoral lug holes. Then slide the appropriate sized collet guide into the housing from anterior to posterior (Figure 21).

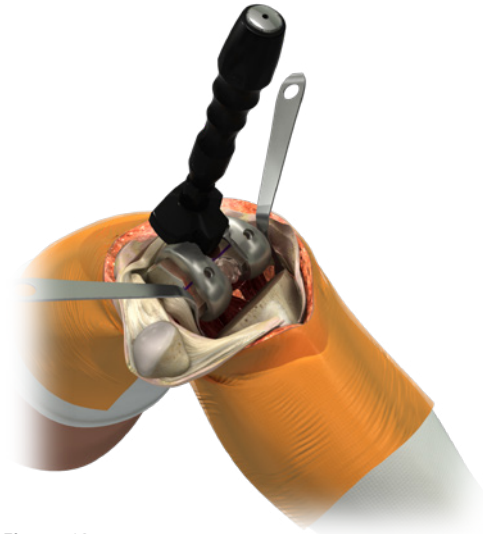

Figure 19

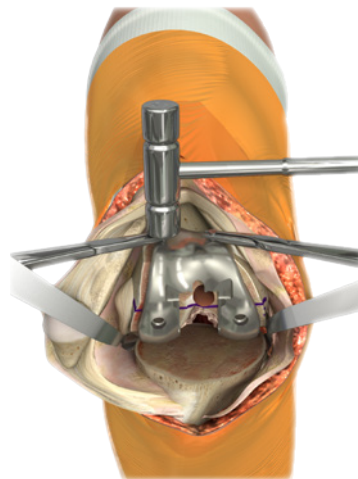

Figure 20

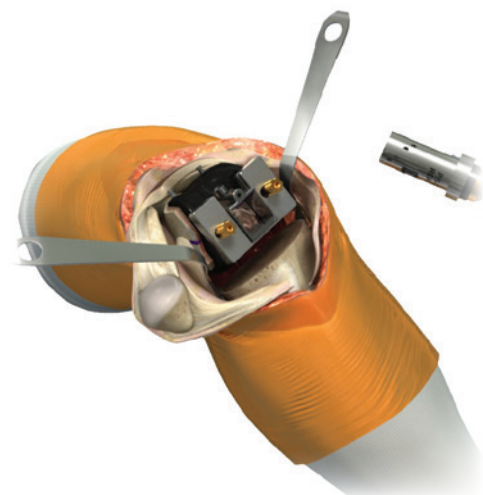

Figure 21

Component trialling *continued*

5. Assemble the PS Housing Reamer by attaching the housing reamer dome and the PS reamer sleeve to the reamer shaft. Ream through the PS Housing Collet in both anterior and posterior positions until the depth stop of the Reamer contacts the PS Housing Collet (Figure 21a).
6. Attach the Modular PS Box Chisel to the Modular Handle and impact through the Collet Guide until flush with the Collet. The Chisel should be used anteriorly and then posteriorly to ensure that the full length of the PS box is prepared. Remove any remaining bone debris within the box preparation area.

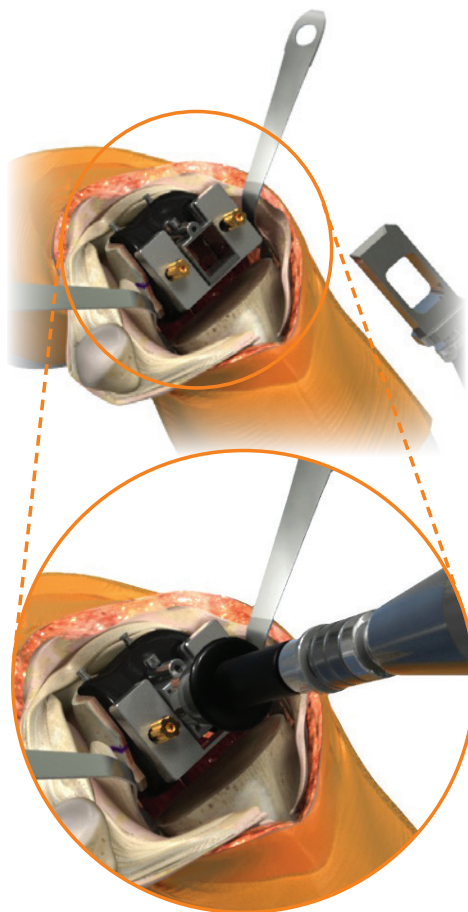

Figure 21a

7. Select the appropriate sized femoral trial PS cam module (matching the femoral trial size selected). Insert the arms of the femoral trial PS cam module into the anterior aspect of the femoral trial box and push posteriorly until seated (Figure 21b).

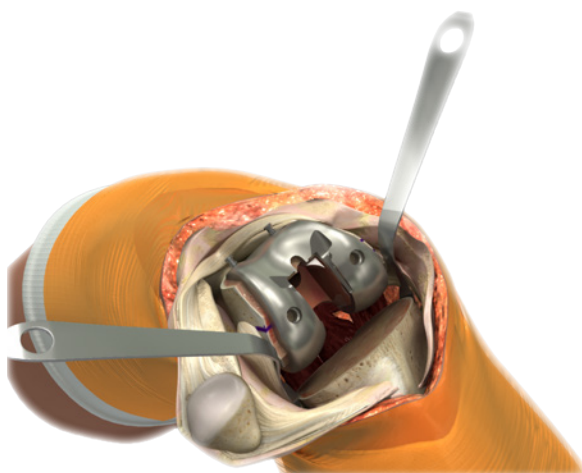

Figure 21b

- Place the appropriate size and desired thickness articular insert trial onto the tibial trial. For Insert thicknesses greater than 9mm select the appropriate shim. Attach the quick connect handle to the tibial trial and insert the assembly into the knee (Figure 22).

Note: The best technique is to flex the knee to 120°, push in the insert as far as possible and bring the leg out into full extension.

- Perform trial range of motion and assess laxity and balance. The knee should drop passively into full extension. Under varus/valgus stress, there should be approximately 1-2mm of gapping both medially and laterally throughout the range-of-motion. There should be no increase in resistance as the knee flexes from 0° to 90°. If the knee is too tight, try a thinner insert or resect more tibia.

Note: Under full varus or valgus stress, the gapping should be at least the width of a cautery tip (~2mm).

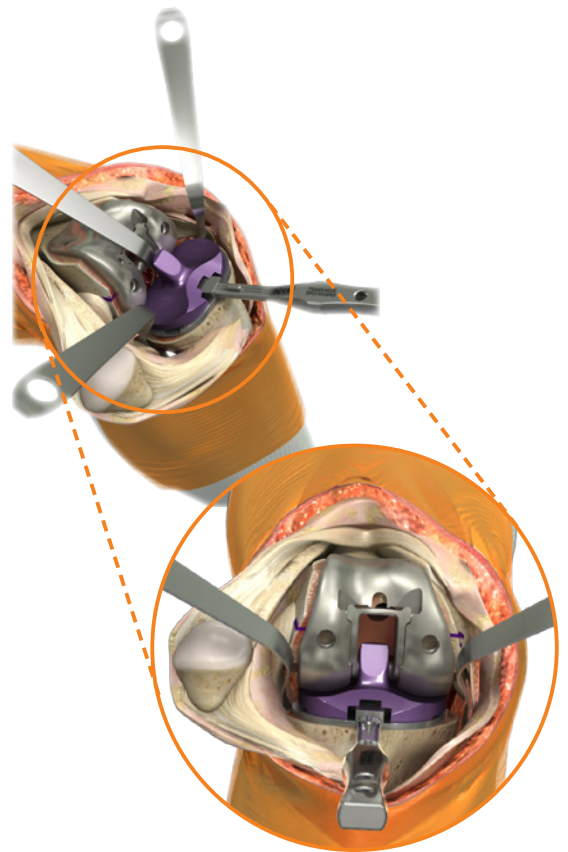

Figure 22

- Long leg alignment can also be assessed by bringing the leg into full extension and passing the alignment rods through the quick connect handle.
- Use a cautery to mark the location of the laser marked lines on the anterior surface of the tibia to reference the baseplate rotation (Figure 22a).

Note: In most cases, rotational alignment of the tibial baseplate based upon best fit and coverage, medial third of the tubercle and the cautery mark will all match.

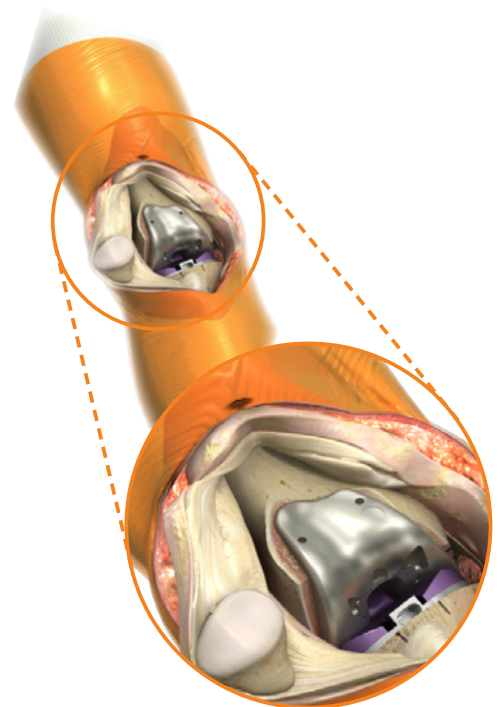

Figure 22a

Tibial keel preparation

1. Once the trial assessment is complete and final implant sites determined remove the insert trial and, if necessary, the femoral trial (Figure 23).



Figure 23

2. Re-assess the tibial coverage, size and rotation required and pin the tibial trial baseplate in place using two short headed pins (Figure 24).



Figure 24

3. Using the 11mm tibial drill, drill through the central canal of the tibial trial (Figure 24a).

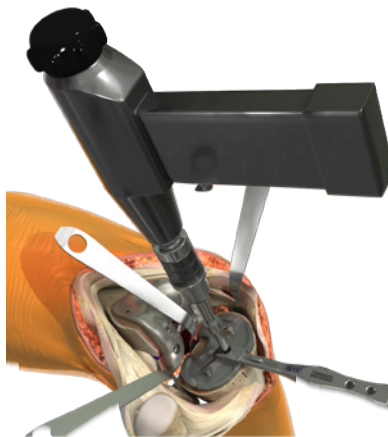

Figure 24a

4. Select the appropriate modular fin punch to prepare the keel and attach to the modular handle. Keel punch through the baseplate. To remove the keel punch, disengage the modular handle and then use the slap hammer to remove from the bone (Figure 24b).

Note: An alternative method to setting tibial rotation is to use the tibia trial bullet. This can be used once the central canal has been prepared but before the keel preparation. With the tibial trial not pinned to the tibial surface, insert the bullet into the prepared canal, insert a 9mm trial articular surface and the appropriate femoral trial. Assess baseplate rotation and use a cautery to mark correct position. Then pin and prepare keel as described above (Figure 24c).

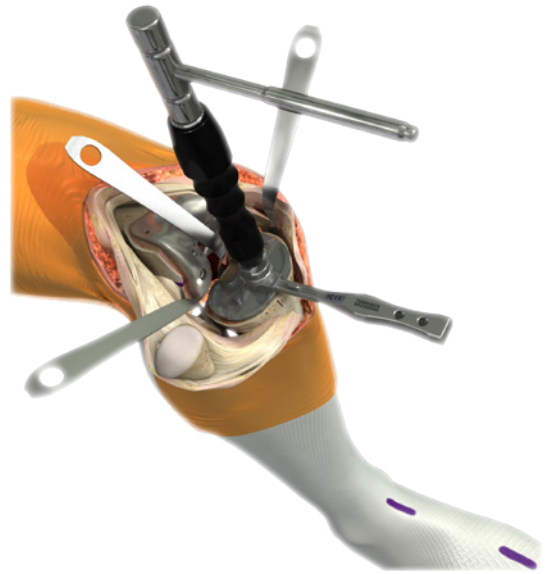

Figure 24b



Figure 24c

Resurfacing patellar preparation

1. Rotate the patella to 90°. Trim tissue surrounding the patella using electrocautery.
2. Use a rongeur to remove osteophytes and reduce the patella to its true size. The electrocautery should also be used to release soft tissue attachments to the estimated level of resection.
3. Measure patellar thickness with the patellar calipers.

Note: The ANTHEM® resurfacing patella is 9mm thick for all sizes (Figure 25).

4. Subtract 9mm from this measured thickness. This is the amount of bone that will remain after resection (Figure 25a).
5. Set the patella resection guide for the amount of bone that should remain after resection. The guide is set at this level by turning the knurled knob (Figure 25a).

For example:

- A.** Measure the overall thickness of the patella with the patellar caliper. For this example, the patella measures 25mm.
- B.** Subtract the thickness of the ANTHEM resurfacing patellar component. In this example, 9mm ($25\text{mm} - 9\text{mm} = 16\text{mm}$). The guide should be set at 16mm.

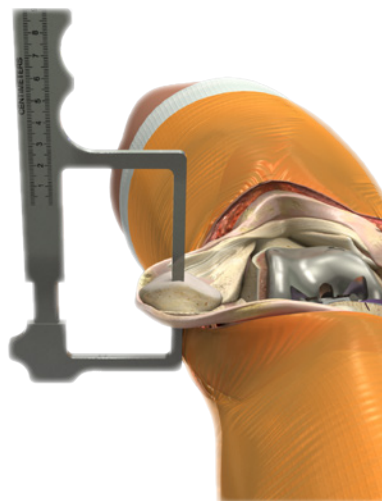

Figure 25

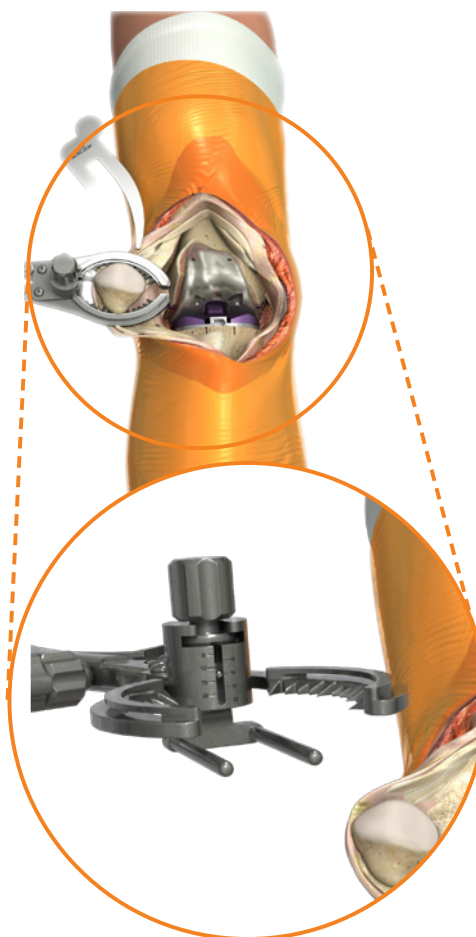
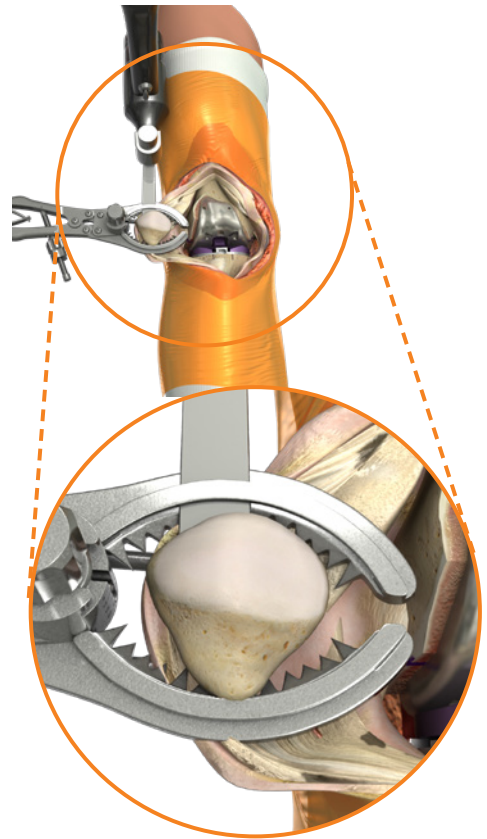

Figure 25a

6. Cut the patella through the dedicated saw guides (Figure 25b).
7. Select the appropriate diameter resurfacing patella drill guide and place it onto the patella. Align patella drill guide to the resected patella.



8. Use the patella peg drill to drill for the three peg holes through the patella drill guide until the drill bottoms out in the guide (Figure 25c).

Figure 25b

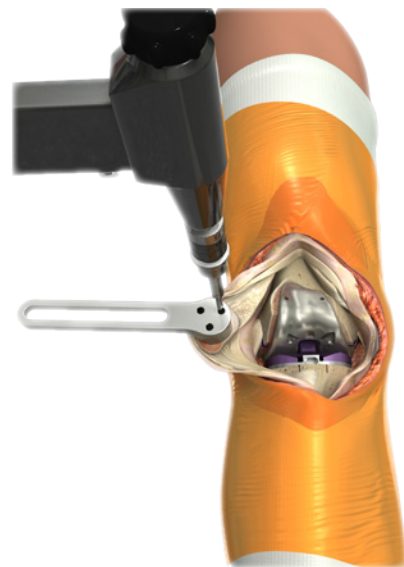

Figure 25c

Resurfacing patellar preparation *continued*

9. Remove the patella reamer guide and drill guide from the patella. Place the resurfacing patellar trial onto the resected patella. Use the patella caliper to reassess the patella thickness (Figure 25d and 25e).
11. Revert back the patella onto the femoral trial to check patella-femoral articulation by flexing and extending the knee several times.



Figure 25d

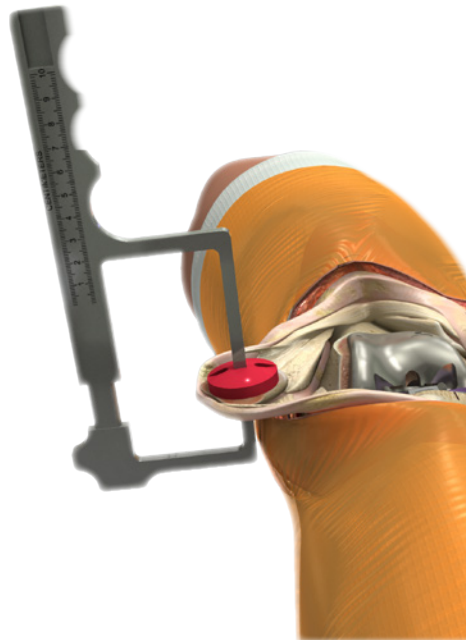

Figure 25e

Implantation and closure

1. Maximally flex the knee and place a thin bent Hohmann retractor laterally and medially and an Aufranc retractor posteriorly to subluc the tibia forward (Figure 26).
2. Apply generous amounts of cement to the dry underside of the baseplate, keel and onto the proximal tibia and keel prep hole (Figure 26).

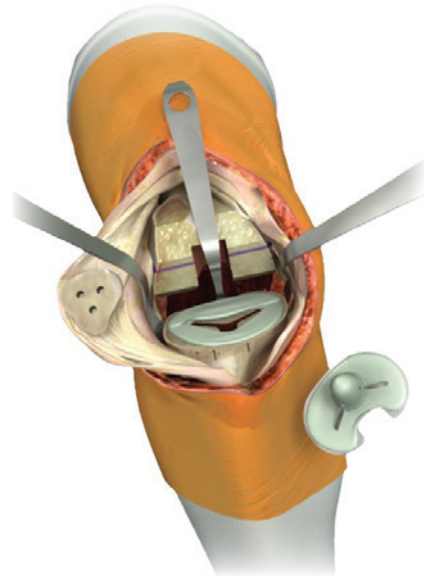

Figure 26

3. Use the tibial implant impactor on the modular handle and mallet to fully seat the tibial baseplate component onto the proximal tibia. Remove excess cement (Figure 27).

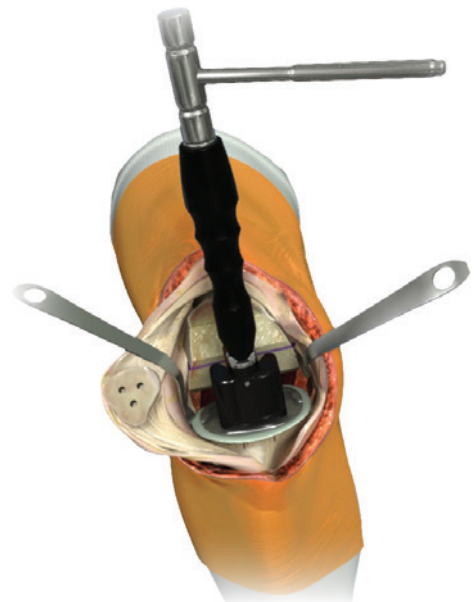

Figure 27

Implantation and closure *continued*

4. Flex the knee to 90° keeping the thin bent Hohmann laterally and removing the Aufranc retractor. Mix and prepare bone cement for femoral component and distal femur. Apply cement to the femoral component or prepared bone, based on the surgeon's preference (Figure 28).

Note: Care should be taken to avoid excess cement on the posterior aspect of the femur and femoral component. Excess cement that extrudes posteriorly is difficult to remove.

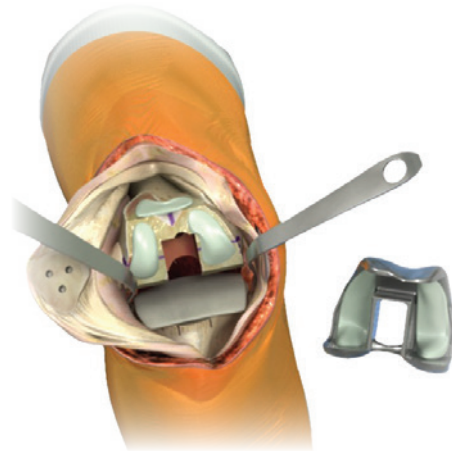

Figure 28

5. Place the Femoral Implant onto the femur and use the Modular Femoral Impactor to fully seat the implant. Remove excess cement. Extend the knee to remove cement anteriorly without retracting the proximal soft tissue (Figure 29a).

Note: Similar to the femoral trial impactor, the femoral implant impactor can be used to impact into the femoral notch as well as on to the distal surface of the component by rotating through 180 degrees. This can be used to prevent the component tilting into flexion during impaction.

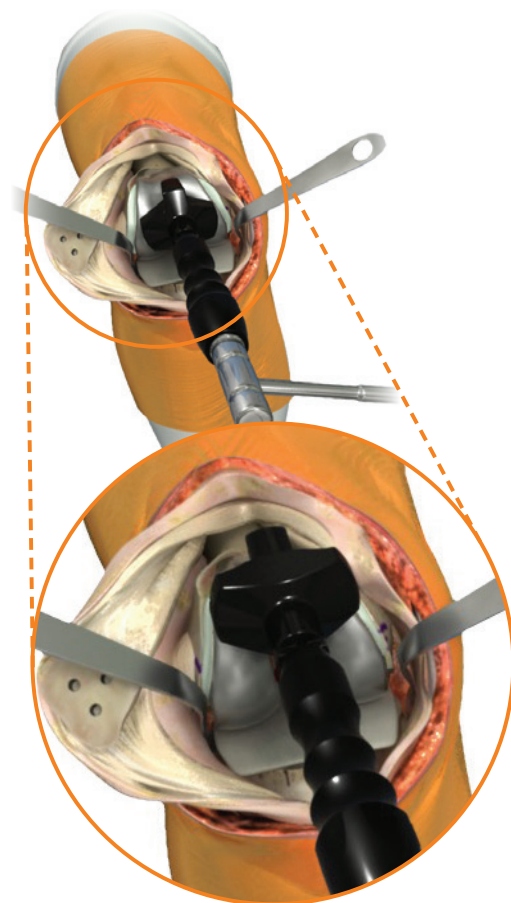

Figure 29a

6. Place the appropriate size Insert trial onto the tibial implant and extend the leg to pressurize the cement. Remove any additional excess cement (Figure 29b).
7. Apply bone cement to the patella. Place the patellar implant onto the patella and clamp into the bone. Remove excess cement (Figure 29c).
8. Select the correct Articular Insert Implant with the appropriate thickness.
9. Clear any debris from the locking mechanism of the tibial implant and slide the articular insert implant into the tibial implant engaging the locking mechanism. Begin insertion in flexion and extend the leg to engage the locking mechanism.
10. The articular insert is locked into position using the modular tibial impactor. This is best done when the leg is flexed to around 20-30 degrees and impacting on the anterior surface of the insert (Figure 29d).

Note: To check insert is fully seated, perform a visual examination on each side of the insert slot. This area will have no visible gap.

11. Check fixation and close.

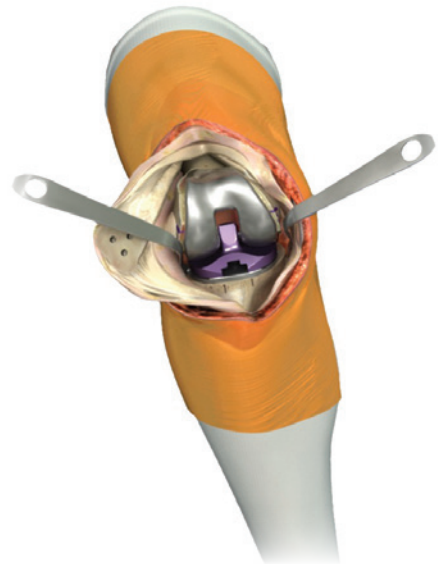

Figure 29b



Figure 29c

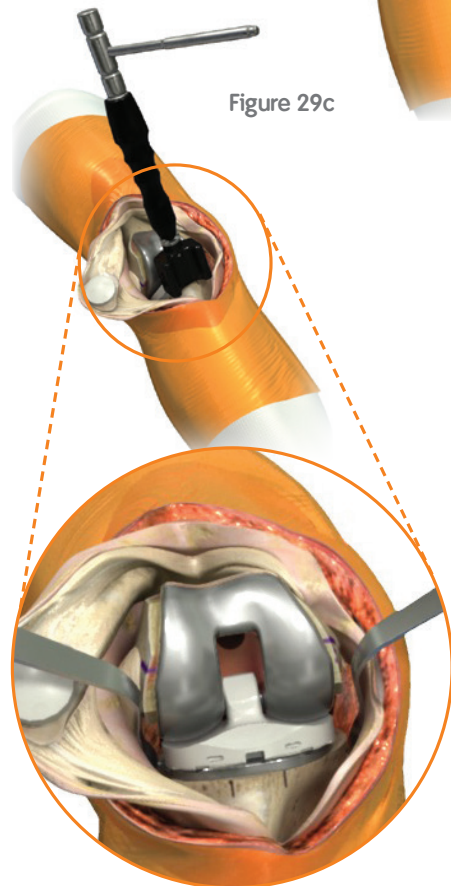

Figure 29d

Tibial preparation

1. Assemble the 3° cut block connector and tibial spiked fixation rod to the extramedullary tibial alignment guide and ankle clamp (Figure 30).
2. Connect the universal cutting block to the 3° cut block connector with the “T” mark facing outwards. This can be attached either centrally or medially depending on preference.



Figure 30

3. Place the ankle clamp around the patient's ankle distally, and proximally impact the posterior spike of the tibial spiked fixation rod into the ACL footprint to secure assembly (Figure 31).

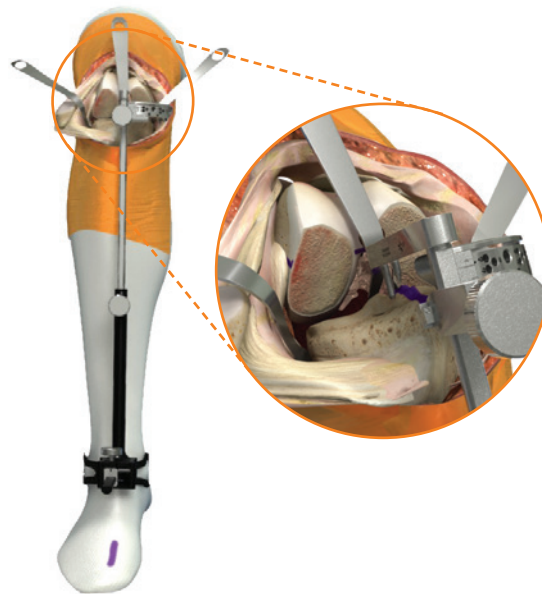

Figure 31

4. Align the extramedullary tibial alignment guide parallel to the tibial axis in the coronal and sagittal planes. Rotate the assembly to the medial one-third of the tibial tubercle and impact the anterior spike of the up rod (Figure 31 and 32).

Note: 3° of posterior slope is built into the cut block connector and 4° of slope is built into the articular insert.

5. Attach the tibial stylus to the universal cutting block by inserting the foot of the tibial stylus into the cutting slot of the universal cutting block.



Figure 32

6. Adjust the resection level by lowering the universal cutting block until the tibial stylus touches the low point on the less affected side of the tibia. The tibial stylus can be adjusted for 2mm (affected side) or 9mm (unaffected side) tibial resection by reversing its position in the cutting slot of the universal cutting block (Figure 33).

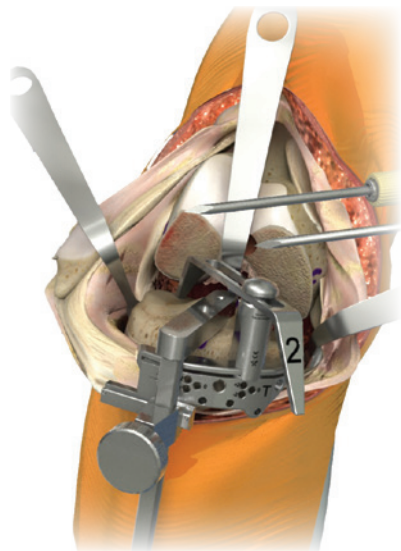

Figure 33

7. Pin the universal cutting block to the tibia by inserting pins first through the central holes; then the medial hole (Figure 34).

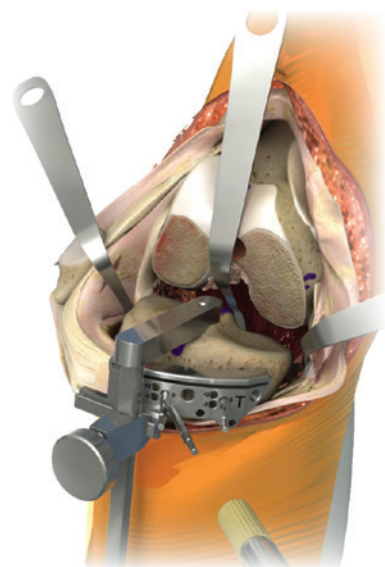

Figure 34

Tibial preparation *continued*

8. Check the posterior slope and resection plane with resection check (angel wing) (Figure 35).
9. Remove the extramedullary tibial alignment guide assembly by loosening the thumbscrews and then using the slaphammer to remove the spike rod superiority while the universal cutting block remains in position with secured pins. The ankle clamp and 3° cut block connector can then also be removed.

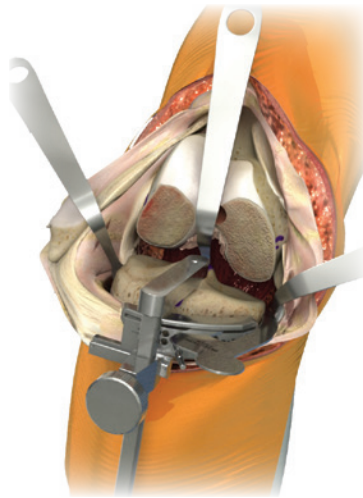

Figure 35

10. Insert drop rod guide assembly into the blade slot of the universal cutting block in mid line of proximal tibia to check mechanical axis alignment (Figure 36).



Figure 36

11. Resect the proximal tibia using an oscillating saw (Figure 37).

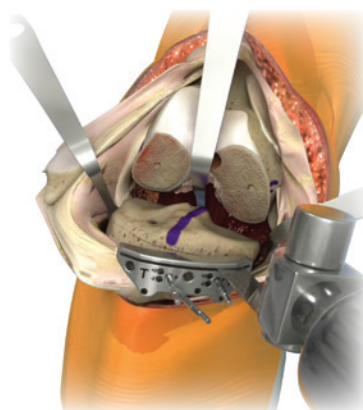

Figure 37

12. Remove the universal cutting block from the bone and clean up the proximal tibial surface (Figure 38).

Note: When a Posterior Stabilized implant is chosen, if it has not already been removed, excise completely the entire PCL attachment from the femoral intracondylar notch with either a cautery or scalpel to prevent it from affecting the assessment.

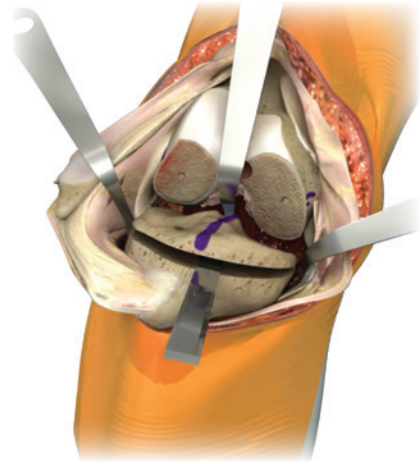

Figure 38

13. Extend the knee to 0 degree to check mechanical axis alignment and extension gap balance. Check alignment and balance with the appropriate spacer block and rod. Balance ligaments in standard fashion (Figure 39).

Note: If the extension gap is too tight for a 9mm spacer, and the distal resection is through the deepest portion of the trochlear groove, resect additional tibia.



Figure 39

Component trialling - Cruciate Retaining resection

The ANTHEM® platform is also available for use with a cruciate retaining procedure.

Component trialling

NOTE: The ANTHEM femoral trials are available in either metal or high grade polymer

1. For cruciate retaining femorals, after completing step 3 of the component trialling section (page 17), prepare the femoral lug holes through the femoral trial with the femoral lug punch (Figures 40 and 41).

NOTE: The ORTHOMATCH Metal Trial Lug Punch is designed for metal trial use only and can not be used to prepare femoral lug holes for the high grade polymer ANTHEM femoral trials. This instrument has text which reads “FOR METAL TRIAL USE ONLY.”

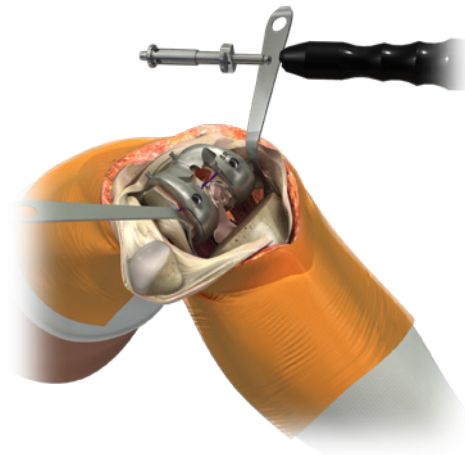

Figure 40

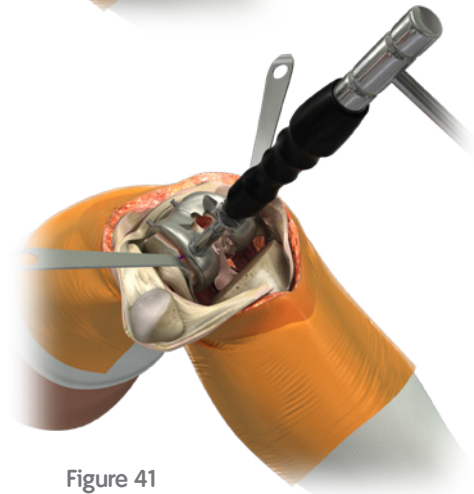

Figure 41

2. Place the appropriate size and desired thickness Articular Insert Trial onto the Tibial Trial. For Insert thicknesses greater than 9mm select the appropriate shim. Attach the Quick Connect Handle to the Tibial Trial and insert the assembly into the knee (Figure 42).

Note: The best technique is to flex the knee to 120°, push in the insert as far as possible and bring the leg out into full extension.

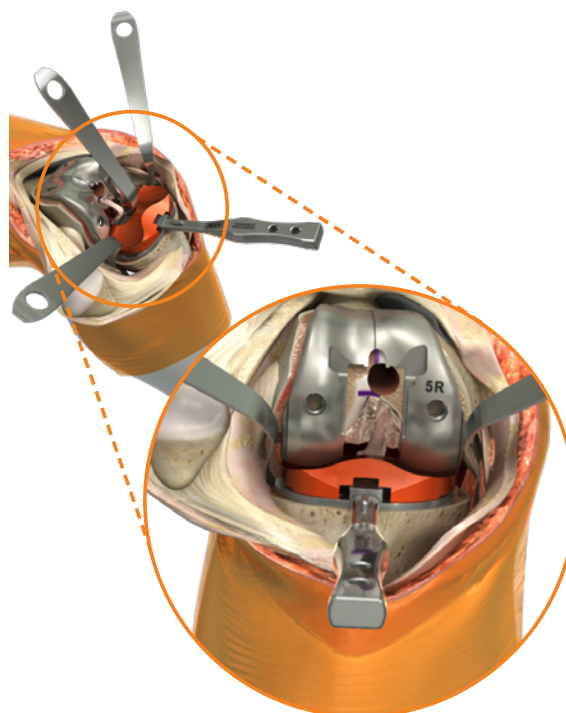

Figure 42

3. Perform trial range of motion and assess laxity and balance. The knee should drop passively into full extension. Under varus/valgus stress, there should be approximately 1-2mm of gapping both medially and laterally throughout the range-of-motion. There should be no increase in resistance as the knee flexes from 0° to 90°. If the knee is too tight, try a thinner insert or resect more tibia.

Note: Under full varus or valgus stress, the gapping should be at least the width of a cautery tip (~2mm).

Note: In most cases, rotational alignment of the tibial baseplate based upon best fit and coverage, medial third of the tubercle and the cautery mark will all match.

4. Long leg alignment can also be assessed by bringing the leg into full extension and passing the alignment rods through the Quick Connect Handle.
5. Use a cautery to mark the location of the laser marked lines on the anterior surface of the tibia to reference the baseplate rotation. (Figure 43)

Note: In most cases, rotational alignment of the tibial baseplate based upon best fit and coverage, medial third of the tubercle and the cautery mark will all match.

Note: Surgical steps for tibial keel preparation and patellar resurfacing are described from page 20 to page 24.

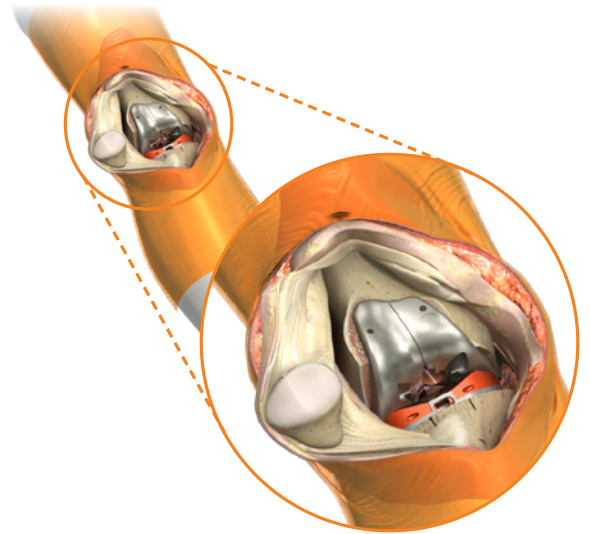

Figure 43

Component trialling - Cruciate Retaining resection *continued*

Implantation and closure

1. Flex the knee to 90° keeping the thin bent Hohmann laterally and removing the Aufranc retractor. Mix and prepare bone cement for femoral component and distal femur. Apply cement to the femoral component or prepared bone, based on the surgeon's preference. (Figure 44)

Note: Care should be taken to avoid excess cement on the posterior aspect of the femur and femoral component. Excess cement that extrudes posteriorly is difficult to remove.

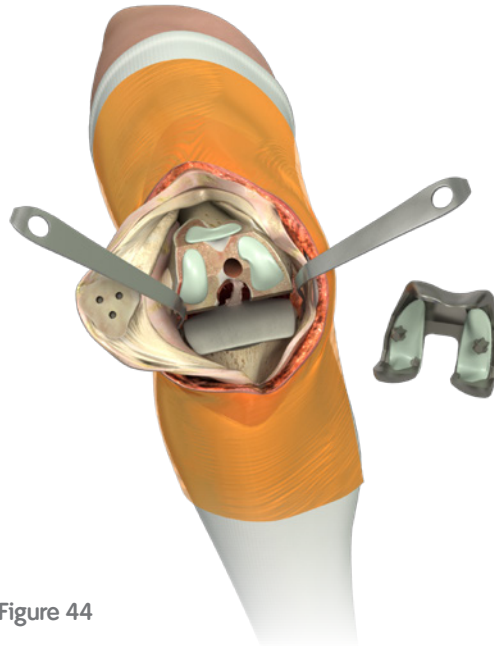

Figure 44

2. Place the Femoral Implant onto the femur and use the Cruciate Retaining Modular Femoral Impactor to fully seat the implant (Figure 45). Remove excess cement. Extend the knee to remove cement anteriorly without retracting the proximal soft tissue.

Note: Similar to the Femoral Trial Impactor, the Femoral Implant Impactor can be used to impact into the femoral notch as well as on to the distal surface of the component by rotating through 180 degrees. This can be used to prevent the component tilting into flexion during impaction.

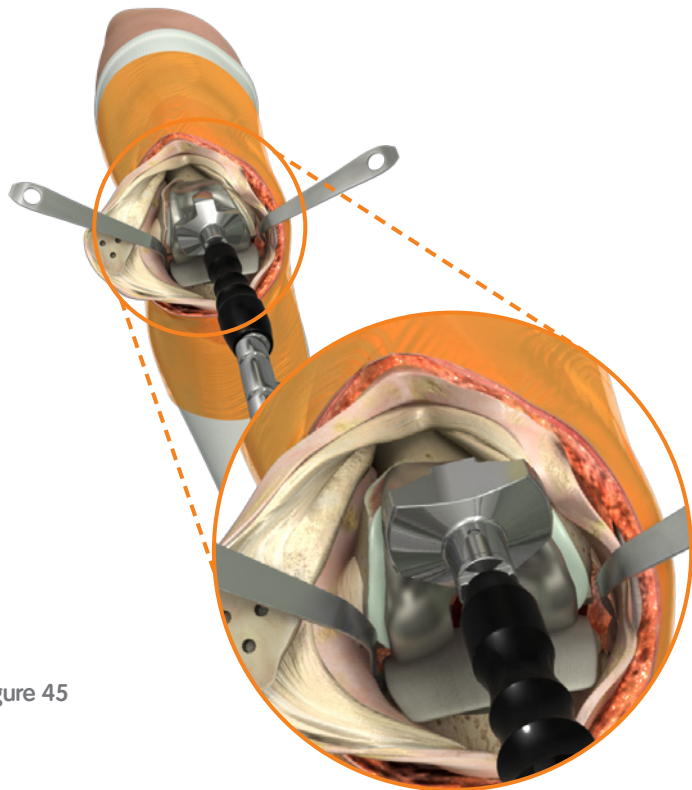

Figure 45

3. Place the appropriate size Insert Trial onto the Tibial Implant and extend the leg to pressurize the cement. Remove any additional excess cement (Figure 46).
4. Apply bone cement to the patella. Place the patellar implant onto the patella and clamp into the bone. Remove excess cement
5. Select the correct Articular Insert Implant with the appropriate thickness.
6. Clear any debris from the locking mechanism of the Tibial Implant and slide the Articular Insert Implant into the Tibial Implant engaging the locking mechanism. Begin insertion in flexion and extend the leg to engage the locking mechanism.

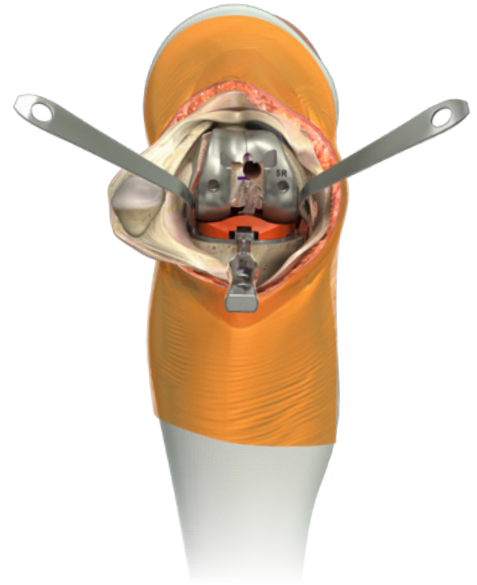

Figure 46

7. The Articular insert is locked into position using the Modular Tibial Impactor. This is best done when the leg is flexed to around 20-30 degrees and impacting on the anterior surface of the insert (Figure 47).

Note: To check insert is fully seated, perform a visual examination on each side of the insert slot. This area will have no visible gap.

Check fixation and close.

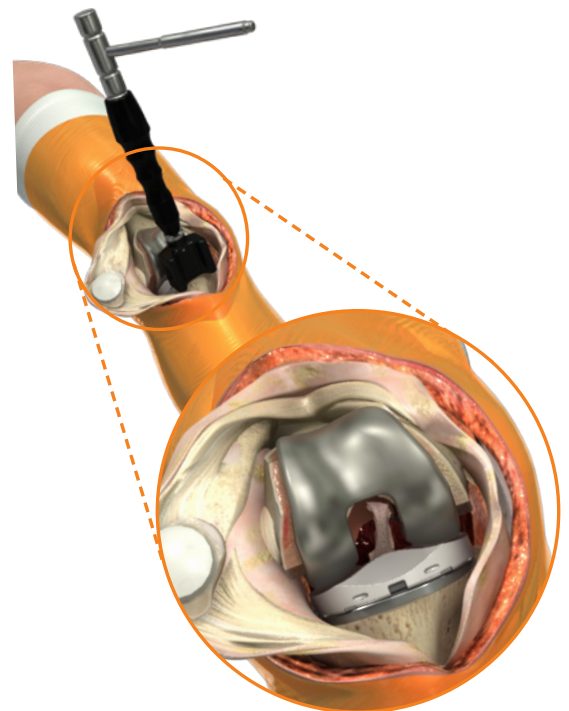

Figure 47

ANTHEM[◊] CR TKS Construct

Recommended Combination

Femoral	Insert	Tibial Baseplate	Patella
ANTHEM Standard CR & Narrow CR CoCr Femoral	ANTHEM CR HF Insert	ANTHEM Tibial Baseplate	GENESIS[◊] II Resurfacing GENESIS II Oval Resurfacing GENESIS II Biconvex

Compatibility with other System Components

ANTHEM Standard CR & Narrow CR CoCr Femoral		ANTHEM CR HF Insert	
Patella GENESIS II Resurfacing GENESIS II Oval Resurfacing	Inserts ANTHEM CR HF Insert GENESIS II CR Deep Flex Insert	Tibial Baseplate ANTHEM Tibial Baseplate GENESIS II Non-Porous Tibial Baseplate	Femoral ANTHEM Standard CR & Narrow CR CoCr Femoral GENESIS II Non-Porous CR CoCr Femoral

Compatibility Table

ANTHEM Component	Compatible Component	Size
ANTHEM Standard CR & Narrow CR CoCr Femoral	ANTHEM CR HF Insert	1-8, 9-18 mm
	GENESIS II CR Deep Flex Insert	1-8, 9-18 mm
	GENESIS II Resurfacing Patella	26-35 mm
	GENESIS II Oval Resurfacing Patella	29-41 mm
ANTHEM CR HF Insert	ANTHEM Standard CR CoCr Femoral	3-8, LT/RT
	ANTHEM Narrow CR CoCr Femoral	1-6, LT/RT
	GENESIS II Non-Porous CR CoCr Femoral	1-8, LT/RT
	ANTHEM Tibial Baseplate	1-8, LT/RT
	GENESIS II Non-Porous Tibial Baseplate	1-8, LT/RT
ANTHEM Tibial Baseplate	ANTHEM CR HF Insert	1-8, 9-18 mm
	GENESIS II CR Deep Flex Insert	1-8, 9-18 mm

ANTHEM[◇] PS TKS Construct

Recommended Combination

Femoral	Insert	Tibia	Patella
ANTHEM Standard PS & Narrow PS CoCr Femoral	ANTHEM PS HF Insert	ANTHEM Tibial Baseplate	GENESIS[◇] II Resurfacing GENESIS II Oval Resurfacing

Compatibility with other System Components

ANTHEM Standard PS & Narrow PS CoCr Femoral		ANTHEM PS HF Insert	
Patella GENESIS II Resurfacing GENESIS II Oval Resurfacing	Inserts ANTHEM PS HF Insert GENESIS II PS HF Insert	Tibial Baseplate ANTHEM Tibial Baseplate GENESIS II Non-Porous Tibial Baseplate	Femoral ANTHEM Standard PS & Narrow PS CoCr Femoral GENESIS II Non-Porous PS CoCr Femoral

Compatibility Table

ANTHEM Component	Compatible Component	Size
ANTHEM Standard PS & Narrow PS CoCr Femoral	ANTHEM PS HF Insert	1-8, 9-18 mm
	GENESIS II PS HF Insert	1-8, 9-25 mm
	GENESIS II Resurfacing Patella	26-35 mm
	GENESIS II Oval Resurfacing Patella	29-41 mm
ANTHEM PS HF Insert	ANTHEM Standard PS CoCr Femoral	3-8, LT/RT
	ANTHEM Narrow PS CoCr Femoral	1-6, LT/RT
	GENESIS II Non-Porous PS CoCr Femoral	1-8, LT/RT
	ANTHEM Tibial Baseplate	1-8, LT/RT
	GENESIS II Non-Porous Tibial Baseplate	1-8, LT/RT
ANTHEM Tibial Baseplate	ANTHEM PS HF Insert	1-8, 9-18 mm
	GENESIS II PS HF Insert	1-8, 9-25 mm

Smith & Nephew
1450 Brooks Road
Memphis, TN 38116

Telephone: 901-396-2121
Information: 1-800-238-7538
Orders/inquires: 1-800-238-7538

www.smith-nephew.com

°Trademark of Smith & Nephew.
All trademarks acknowledged.
© 2021 Smith & Nephew.
02903 V6 71282019 REVD 05/21

Supporting healthcare professionals for over 150 years