

JOURNEY[®] PFJ

Patellofemoral Joint with
Oxidized Zirconium

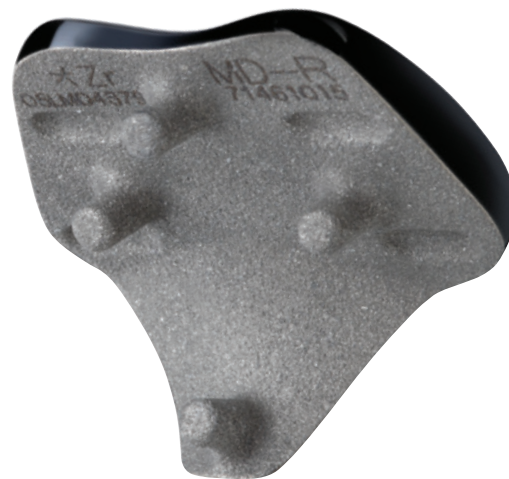
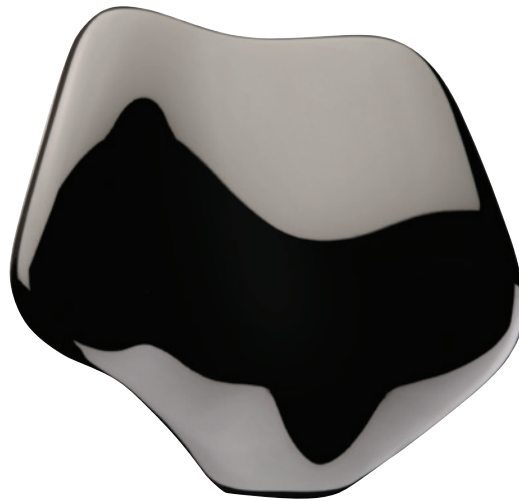

Surgical Technique

JOURNEY[◇] PFJ

Patellofemoral Joint with

OXINIUM[◇] Oxidized Zirconium

Contents

Product Overview.....	2
Surgical Principles	5
Surgical Technique	6
Rotational Alignment	
Method 1: Tibial Referencing	8
Method 2: A/P Axis/Epicondylar Axis Visualization	9
Resurfacing Patellar Preparation.....	16
Biconvex Patellar Preparation	18
Catalog Information	20
Implant Compatibilities.....	22

Designing/Contributing Surgeons

Jeffrey R. Dugas, MD

Fellowship Director
American Sports Medicine Institute
Birmingham, Alabama
Orthopaedic Surgeon
Alabama Sports Medicine and
Orthopaedic Center
Birmingham, Alabama

E. Lyle Cain, Jr., MD

Fellowship Director
American Sports Medicine Institute
Birmingham, Alabama
Orthopaedic Surgeon
Alabama Sports Medicine and
Orthopaedic Center
Birmingham, Alabama

John Newman, FRCS

Avon Orthopaedic Centre
Bristol. UK

William B. Smith, MD

Associate Clinical Professor in
Orthopaedic Surgery
Medical College of Wisconsin,
Columbia St. Mary's
Milwaukee, Wisconsin

Nota Bene

The following technique is for informational and educational purposes only. It is not intended to serve as medical advice. It is the responsibility of treating physicians to determine and utilize the appropriate products and techniques, according to their own clinical judgment, for each of their patients. For more information on the product, including its Indications for Use, contraindications, cleaning, sterilization and product safety information, please refer to the product's label and the Instructions for Use (IFU) for the product.

Product Overview

The JOURNEY[®] knee system is comprised of a family of implants designed to treat localized areas of arthritis, often seen before tricompartmental arthritis has developed. Rather than proceed immediately to TKA, the surgeon can choose from a range of implants that treat either the medial or lateral condyle, the patellofemoral joint or the medial condyle and PFJ simultaneously. This level of selective arthroplasty is further enhanced with the use of OXINIUM[®] Oxidized Zirconium, an advanced bearing surface for uni and bi-compartmental disease.

The JOURNEY PFJ is part of this family of implants. It is designed to treat patellofemoral OA and restore normal patellar tracking. There are four sizes: extra small, small, medium and large. The implants are asymmetric to reproduce the normal anatomy's lateralized tracking of the patella.

The bone-sparing instrumentation is markedly improved over previous systems, including a unique resurfacing trochlear reamer. The location of the four fixation pegs on the femoral component is identical for all sizes, allowing for seamless intraoperative upsizing or downsizing of the femoral component in the latter stages of the procedure.



AP view



ML view

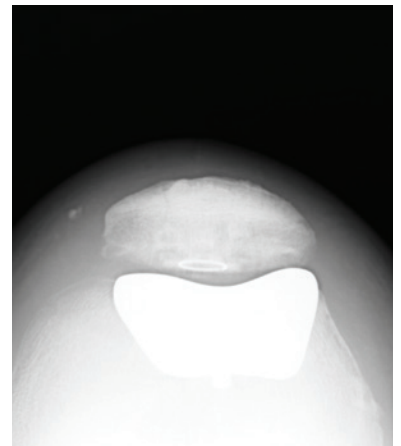

Sunrise view

Rehabilitation

In the majority of cases rehabilitation follows a routine post knee replacement regimen with early range of motion exercises and full weight bearing. Surgeons should use their usual protocols with regard to antibiotic and thromboembolic prophylaxis. Many patients will have had long standing anterior knee pain and quad dysfunction, so rehabilitation may be slower than expected and more analgesic may be required. In addition, it is hard to avoid some insult to the quadriceps mechanism so rehabilitation at the same speed as following a minimally invasive unicompartmental replacement will not be achieved. Using a lateral approach avoids interference with the vastus medialis and may facilitate rehabilitation.

In addition if major extensor mechanism realignment procedures such as an Elmslie Trillat have been required then protection with a splint while walking for a few weeks is probably wise, though the knee should be kept moving while the patient is recumbent.

The views and opinions expressed for postoperative care are solely those of the surgeon(s) and do not reflect the views of Smith & Nephew.

Surgical Principles

1. Sizing. The primary means for determining the appropriate size is the ML width of the anterior surface after the cut is made. The system is designed with interchangeable pegs, allowing the full selection of sizes even after peg holes are drilled. The best size will fully cover the anterior surface without overhang. Avoiding overhang is more important than complete coverage. Proximal-distal coverage is less critical. Leaving a small portion of cancellous bone uncovered should not compromise the result.
2. Varus/valgus. Most surgeons will use the AP axis to determine where to align the laser etched line on the trial. Scribing this line on the femur will approximate proper varus/valgus positioning. Final positioning on the patient's own "trochlear" axis is most likely to result in a flush position on both sides of the component – as it interfaces with the patient's chondral surfaces.
3. Rotation. You should attempt to match the native anatomy where possible, which will average 3° but will vary between 1° and 9°. The instrumentation will assist in attaining the optimum rotation.
4. Patella.
 - a. Biconvex or resurfacing? Surgeon preference, both work well.
 - b. Placement? Exactly like you would in a total knee. Keep in mind, that if revised, the surgeon may be able to leave the patellar component in place.
5. Revision to a Primary TKA. The prosthesis lends itself to an uncomplicated revision to a primary total knee. The anterior cut is less than or equal to the standard cut on any TKA. If the cut has a slight bevel – as with the Smith & Nephew GENESIS° II knee, then it is even less of a problem. Furthermore, when the anterior chamfer is made, any residual cement will be removed. There is a clinical history of other patellofemoral prostheses with similar four peg fixation designs, and they have been shown to be easily removed without significant bone loss.¹

Surgical Technique

Preoperative note: If replacing the patella, use a GENESIS[®] II biconvex or round resurfacing implant. Do not use the JOURNEY[®] BCS Total Knee Patellar Component.

1. Open the joint using your standard mid-line or slightly medial parapatellar incision, which is approximately 1" proximal to your "incision" for TKA. Maneuver patella out of the joint space. Some surgeons prefer a lateral incision. The instruments accommodate either.

2. Place the Offset EM Alignment Rod on the anterior femur. The rod goes underneath the quad, on top of the femur, and serves as a guide to ensure that the intramedullary rod is inserted parallel, not breaching the femoral cortex.

At this point, you can free-hand a parallel opening in the canal, or use the "L" shaped drill guide in step 3. The opening needs to be high in the canal, not centered.

3. Using the EM Alignment Rod for visual alignment of flexion, open the femoral canal with the 4.75mm drill. The "L" shaped IM drill guide (shown at right) can be used as an aid in placement and ensuring creation of an opening that is parallel to the canal.

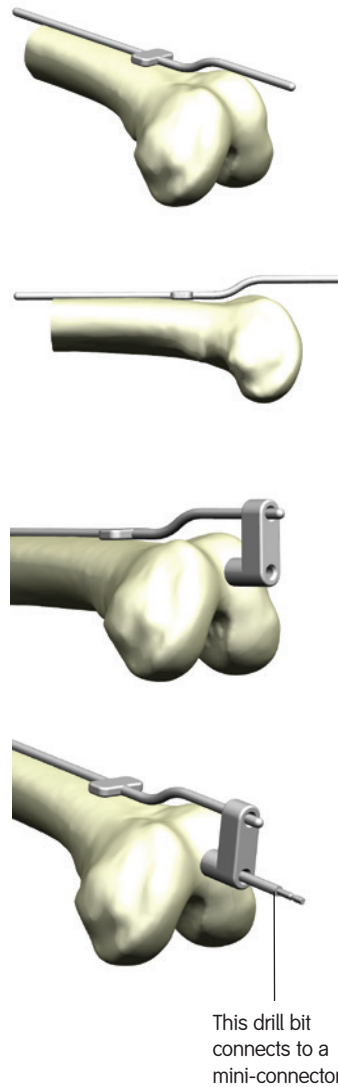

4. Attach the 4.7mm IM Rod to the T-Handle inserter. Place the 4.7mm IM Rod into the opening hole until it stops at the depth stop. Double-check A-P alignment with EM Alignment Rod.

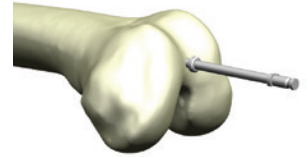

5. Slide the Anterior Cutting Guide onto IM Rod from the medial side until a “click” is heard. Some surgeons, even with a medial incision on a left knee, have preferred the right anterior cutting guide. This is perfectly acceptable; the same anterior cut can be achieved with either guide.

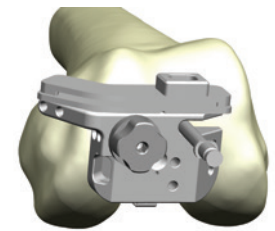
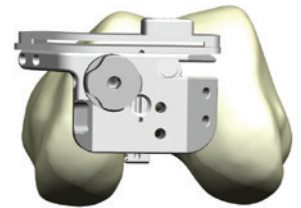

Rotational Alignment

Method 1: Tibial Referencing

6. Draw the AP Axis along the trochlear groove using a cautery or a marking pen. There are both femoral and tibial referencing methods. Tibial referencing is considered the primary method, with the femoral referencing as a secondary check.

7a. Attach the tibiofemoral alignment ankle clamp to the ankle, and align the vertical rod with the tibial shaft. Flex the knee to 90°. Determining femoral component rotation by referencing a line perpendicular to the longitudinal tibial shaft axis is supported by clinical studies.²



7b. Align the platform on the top of the alignment guide with the bottom face of the Anterior Cutting Guide. The platform should be flush or nearly flush with the bottom of the anterior cutting guide. In proper alignment, there is typically less than 1° or 2° of difference between the femoral and tibial referencing.



7c. When pinning the guide, a pin driver may be desired. Select two or three of the five holes for optimal fixation. One of the holes chosen needs to be the outrigger pinhole. Please see step 8 for more detail on pinning the Anterior Cutting Guide.



7d. A shorter pin is included in the set for the medial outrigger.



Method 2: A/P Axis/Epicondylar Axis Visualization

- 7e. Attach the Quick Connect Handle to the pocket on top of the Anterior Cutting Guide by depressing the gold button on the handle.
- 7f. Slide the long axis of the Alignment T-bar through one of the holes in the quick connect handle all the way until it snaps on around the quick connect handle.
- 7g. Using the T-Bar as a visual guide, align the Anterior Cutting Guide in 0° - 3° of external rotation. A second quick connect handle can be attached to the medial part of the cutting guide to stabilize while pinning.
- 7h. If you are satisfied with the alignment at this point, you can choose to go ahead and pin the guide. Pinning guidelines are in step 8. Tibial referencing is a secondary check, detailed on the next page.

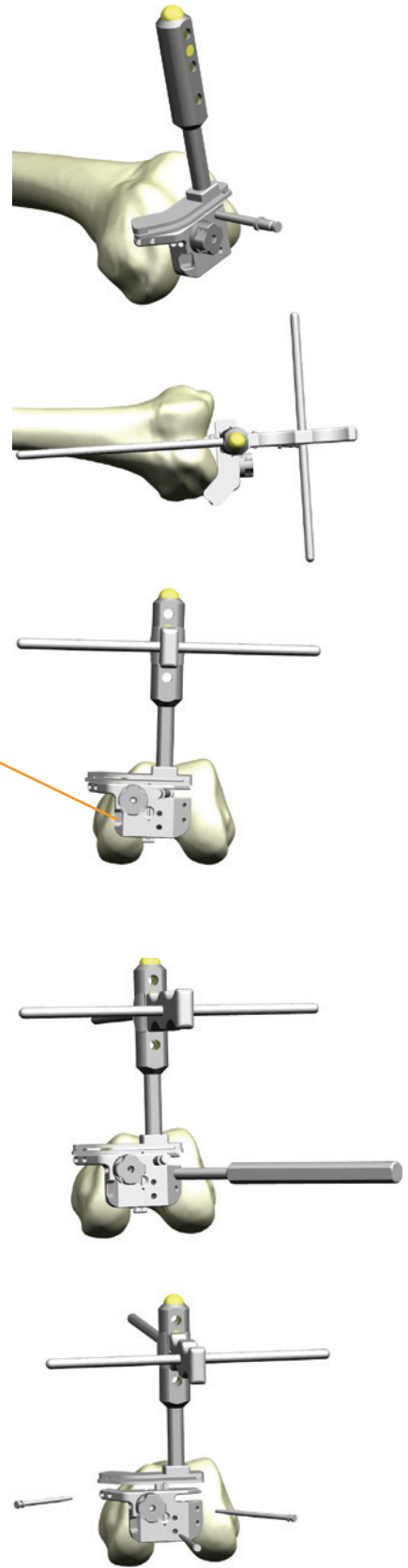

8. Pin the Anterior Cutting Guide using the headed pins provided in the set. It is helpful to pre-drill the pin holes to prevent twisting of the guide when impacting the pins into place. Two to three pins, one of which is inserted in the medial outrigger pinhole, are sufficient to assure stability.

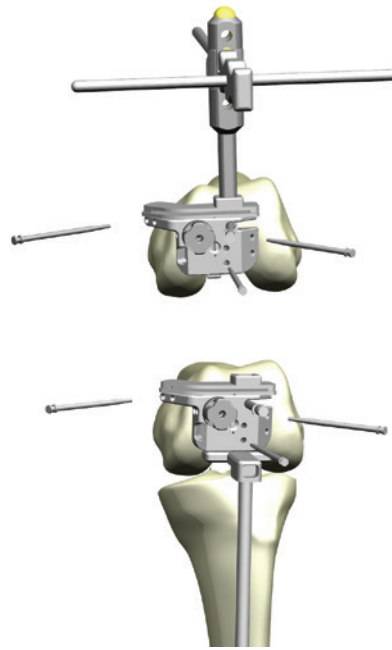

9. There are numerous methods for sizing the femoral implant with Anterior Cutting Guide and the associated sizing stylus. For a more conservative measurement, place the sizing stylus on the anterior aspect of the lateral femoral condyle. For a more aggressive resection, place the stylus in the sulcus of the anterior trochlea of the femur. For both methods, the goal is to create a smooth resection on the anterior femur without notching. Turn knob to adjust height. Height may also be checked with the Resection Check (angel wing) in the cutting slot. When proper height is reached, use the hex driver to tighten the set screw and lock the cutting guide in place. Resect the anterior femur.

Note: the adjustable nature of this guide allows you to undercut and then shave down sequentially to make every resection ideal.

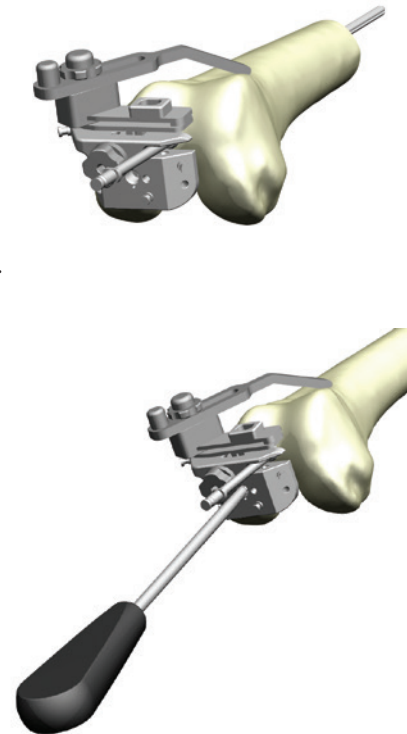

10. Size the femur by placing the appropriate drill guide onto the femur and judging the fit. If desired, a Quick Connect handle can be placed in the drill guide. Using a cautery, mark the location of the laser mark on the top of the drill guide. Drill preparation holes for the reamer guide through the proximal two holes marked with bull's-eyes and pin in place with **headless** pins. Mark the intercondylar region with a cautery or marking pen. Remove the Drill Guide by sliding over the pins. Leave the pins in place.

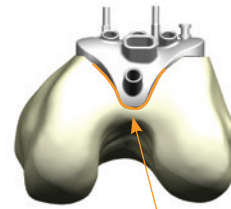
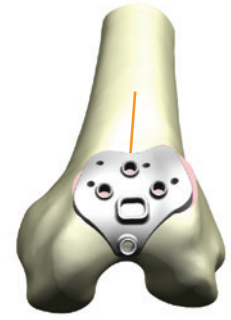

Mark intercondylar edges with cautery or marker

11. Place the reamer guide onto the cut surface, sliding the guide over the pins into the slots in the reamer guide until the tip of the guide touches the intercondylar region and can not slide any further. Removing a small amount of bone or cartilage from the notch can sometimes help to fully seat the reamer guide. Align the laser line on the center of the anterior surface with the appropriate (L or R) cautery mark made in Step 10. Assure that the reamer guide sits flush against the anterior cut surface. Pin one additional headed short pin in one of the open holes to secure the device. Place one pin into the trochlear region through the distal portion of the resection guide. There are three holes to choose from, but only one hole can be selected.

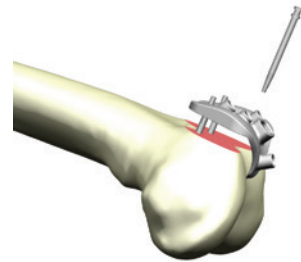

Align cautery mark with the appropriate laser mark on the guide

Short-headed pin (under the pin driver in this image) assures stability

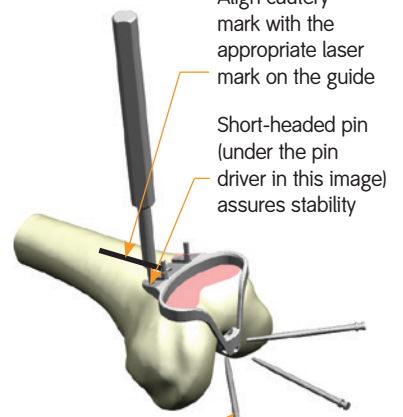

Choice of three holes, but only one can be used at a time

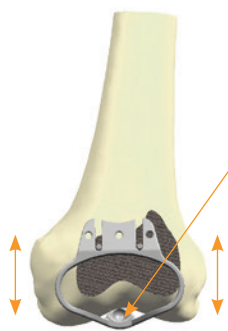

Placement of the reamer guide will decide how much or little trochlea bone is removed

Keeping the tip out of the notch will prevent going too deep with the first reamer and will allow the deeper reamers to be used in the event more depth is needed

12. Attach the Yellow Reamer Sleeve to the reamer shaft as shown. Attach the reamer to the drill. In most cases, the yellow sleeve will be all that is required to achieve adequate depth. Use your depth gauges often to avoid over reaming. Over reaming may make the patella jump as it changes from one surface to the other. The darker the sleeve, the deeper you ream. The order of reamer sleeves is Yellow = standard, Green = +1mm, Blue = +2mm. Darker is deeper.



13. Place the round reamer tip into the round depression in the reamer guide and ream the trochlear region from medial to lateral and back. Using a small amount of force to keep the reamer in contact with bone, ream up to but not touching the cautery/marker lines that denote the outer boundary of the implant that were made in step 10.

TIP: Instead of immediately going back and forth across the reamer guide, some surgeons prefer to bring the reamer directly towards the guide in a straight line until the sleeve reaches the guide, and then begin the side to side motion. This technique can facilitate reaming and let the surgeon focus on resurfacing just to the tide marks.

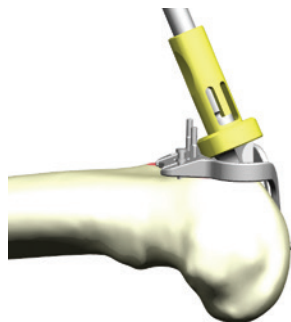
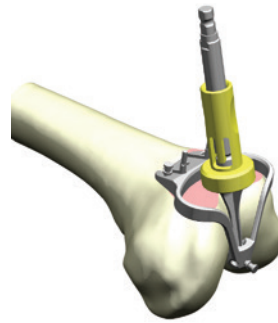

You only have to ream to the mark, not to the sides of the guide.



Reaming is complete once the sleeve maintains contact with the guide throughout the range of motion to the edges of the intended implantation site. In many cases, you will only need the first sleeve to achieve the necessary depth for a smooth transition zone.



14. When the yellow reamer sleeve will not allow any further reaming depth, remove the reamer from the guide and place the Trochlear Depth Gauge into the reamed region to judge the reaming depth and transition zone. If more bone removal is necessary, the Green +1mm sleeve or Blue +2mm sleeve may be used to increase the depth and width of the reamed area. In most cases, the yellow sleeve will be sufficient. Check reaming depth each time with the Trochlear Depth Gauge before switching to a more aggressive reamer sleeve.

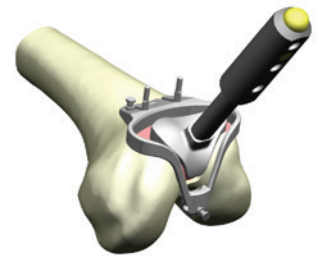

15. When reaming is complete, place the drill guide onto the femur. If necessary, the Putti Rasp may be used to fine-tune the component fit.
- a. If desired, pins can be inserted through the laser-etched smaller holes to stabilize the guide. If it is preferred to avoid these pins, alignment pegs may be used. These are exactly the same depth as the implant pegs, so no unnecessary pinholes are created.

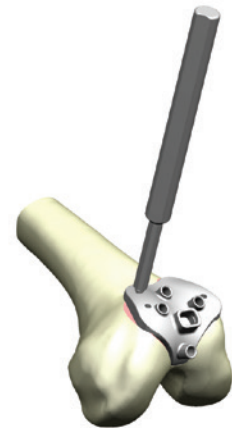

- b. Use the Peg Drill to drill the first peg hole in the top of the implant. The suggested order is top, bottom, then both sides.

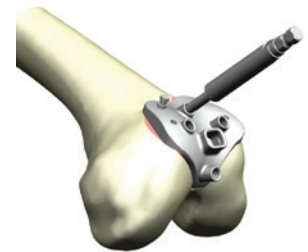

- c. Once drilled, insert an Alignment Peg in the hole to stabilize the guide.

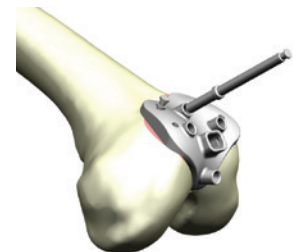

- d. Repeat the drill and fill process in the bottom hole.
Drill the bottom hole with the Peg Drill.

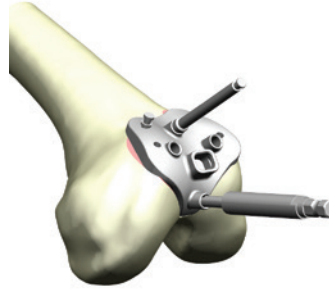

- e. Insert another Alignment Peg, leaving the top Alignment Peg in place as well.

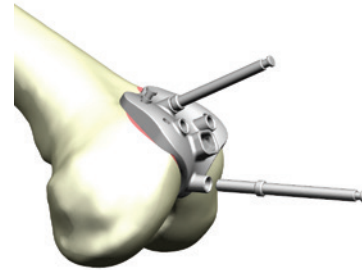

- f. Drill the third hole.

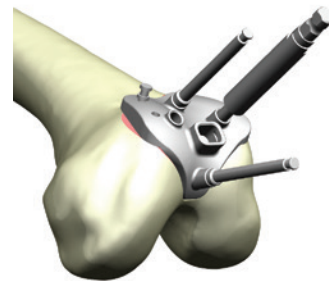

- g. Drill the fourth hole.



16. Place femoral trial. Begin by inserting the distal/posterior hole and lever the trial into place, using light taps on the impactor to seat the component.



In most cases, the bone will be soft enough to lever the trial in place. With hard or eburnated bone, it may be necessary to open up the inferior portion of the top three holes with a drill in order to seat the component.



This design fits tightly. Take care when removing the trial. Start by lifting the proximal end.

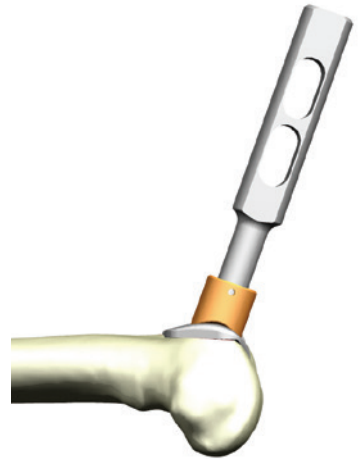

17. Prepare patella with same technique and instruments as a standard GENESIS[®] II Total Knee Replacement.
Do not use the JOURNEY[®] BCS Total Knee Patellar Component.
18. Perform a trial range of motion with the trial components in place.
19. When appropriate joint balance is obtained, cement the femoral and patellar implants in place and close the wound. Correct tracking is essential, and releases may well be required, particularly if a medial incision has been used.

Resurfacing Patellar Preparation

The surgeon can choose from a free hand cutting technique with towel clips or if desired he or she can choose one of the following instrumented techniques.

Resection Guide Technique

1. Measure the overall thickness of the patella with the patellar calipers.
2. Subtract from this number the thickness of the GENESIS® II round resurfacing patellar component – 9mm.
3. The guide is set at the amount of bone that needs to remain after cutting the patella – i.e. the difference between the original patellar thickness and 9mm. The guide is set at this level by turning the knurled knob.

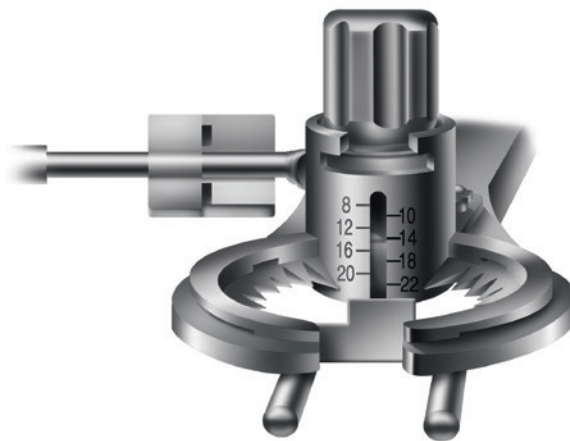

4. Cut the patella through the full dedicated saw guides.
5. Drill for the three pegs, insert the resurfacing patellar trial and remeasure. The overall thickness should be equivalent to the original thickness.

Reaming Technique

The reaming technique described for the biconvex patella can be used as well. The only differences in technique are to use the red resurfacing depth gauge, resurfacing reamers and the resurfacing drill guides.



Biconvex Patellar Preparation

Biconvex Patella

Instrument Assembly:

Determine the appropriate diameter patellar implant and select the correctly sized patellar reamer collet and slide it into place on the patellar reamer guide.

1. Attach the patellar reamer guide to the patella. Tighten the patellar reamer guide on the patella.
2. Use the patellar calipers to measure the thickness of the patella.

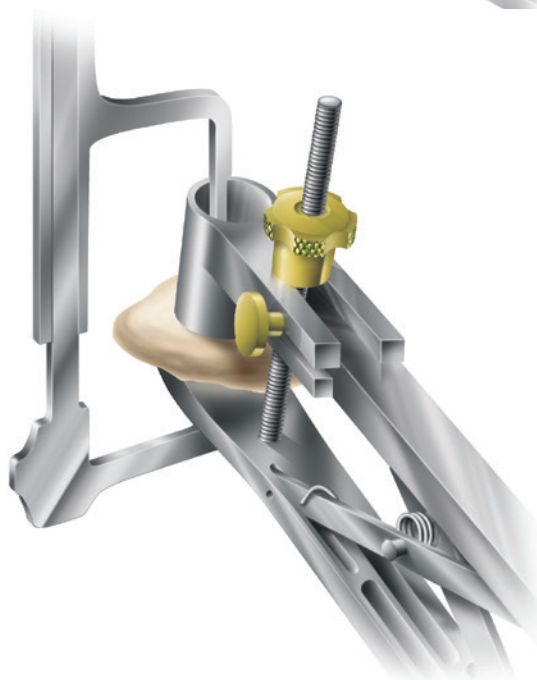
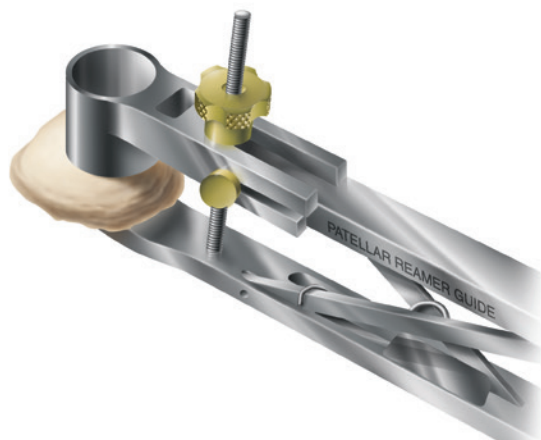
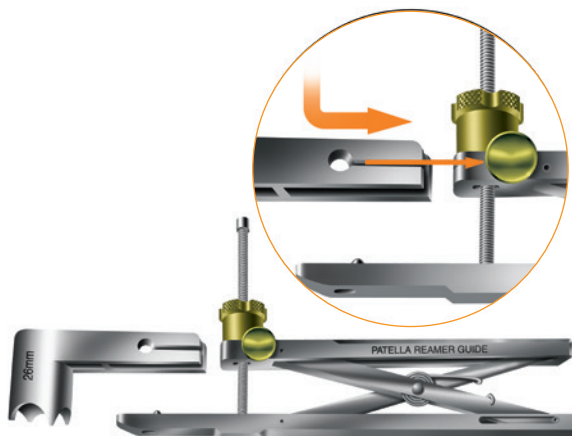

Instrument Assembly:

- a. Attach the blue patellar depth gauge to the reamer guide.
- b. Attach the matching sized patellar reamer dome and patellar depth stop to the patellar reamer shaft. Lower the assembly through the patellar reamer guide until the reamer dome contacts the patella.

3. Swing the patellar depth gauge around so that the “claw” surrounds the patellar reamer shaft.
4. Lower the patellar depth stop by pushing the gold button until it contacts the patellar depth gauge. The patellar depth stop will automatically lock in place (bottom image).
5. Remove the depth gauge.
6. Ream the patella until the depth stop engages the patellar reamer guide. Often in these cases, the patella will be very thin (10-18mm). In those cases, stop well short of the measured resection and remove minimal patellar bone. A shallow rim is all that is required for the inset and you may save 6-8mm of patella for the future.

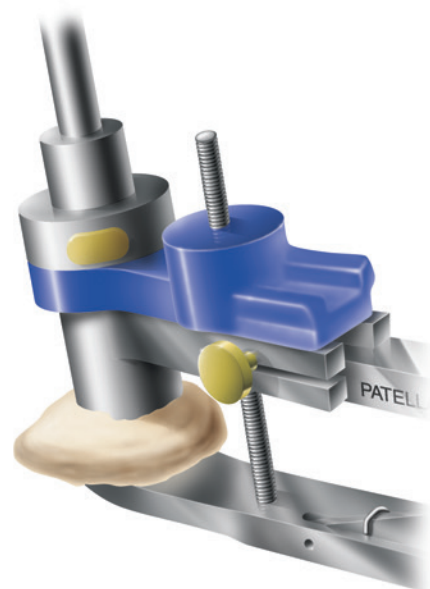
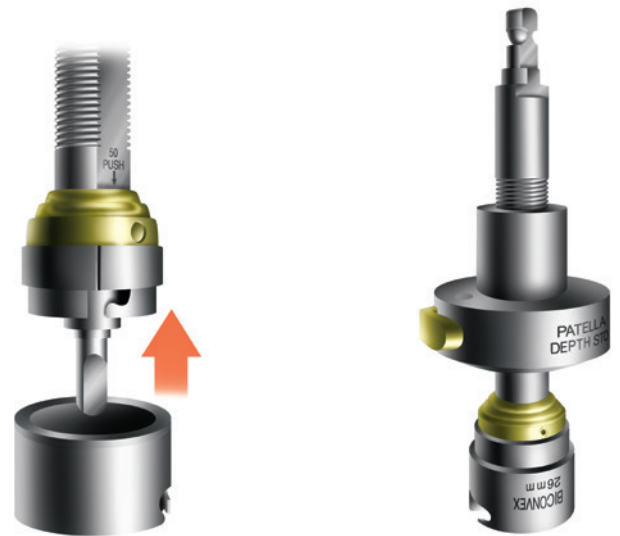
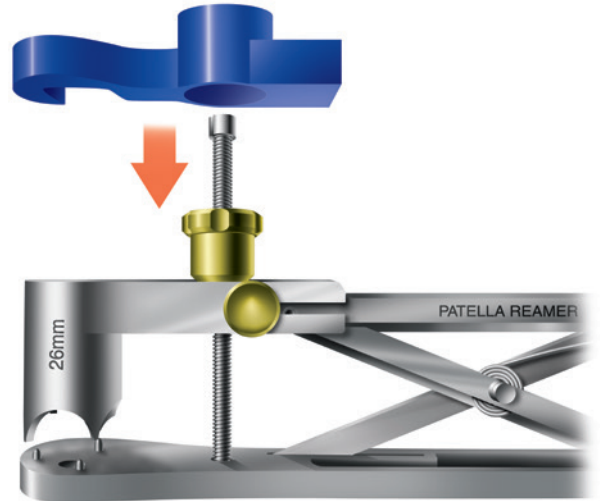

Catalog Information – Instruments

Set number – 71560000

Femoral EM Alignment Rod

Cat. No. 71563409



IM Drill Guide

Cat. No. 71563439



Anterior Cutting Guide Left and Right

Cat. No. 71563410 (Left)

Cat. No. 71563411 (Right)



GENESIS® II Minimally Invasive Anterior Femoral Sizing Stylus

Cat. No. 71441115



IM Rod

Cat. No. 71563412



Resection Check

Cat. No. 74012431



Femoral Drill Guides

Cat. No.

71563401	PF Drill Guide x-small left
71563402	PF Drill Guide x-small right
71563403	PF Drill Guide small left
71563404	PF Drill Guide small right
71563405	PF Drill Guide medium left
71563406	PF Drill Guide medium right
71563407	PF Drill Guide large left
71563408	PF Drill Guide large right



Quick Connect Handle (2)

Cat. No. 71440044



Alignment T-Bar

Cat. No. 71563414



Tibiofemoral Alignment Guide

Cat. No. 71563413



JOURNEY® EM Tibial Ankle Clamp

Cat. No. 74018331



JOURNEY EM Tibial Alignment Guide

Cat. No. 74018311



Hex Driver

Cat. No. 115035



Trochlear Reamer Guide

Cat. No. 71563440



Reamer Sleeve Standard (Yellow)

Cat. No. 71563432



Reamer Sleeve +1mm (Green)

Cat. No. 71563433

Reamer Sleeve +2mm (Blue)

Cat. No. 71563434

Trochlear Reamer

Cat. No. 71563430



Trochlear Depth Gauge (Left)

Cat. No. 71563431



Trochlear Depth Gauge (Right)

Cat. No. 71563421

Left gauge shown

Femoral Impactor

Cat. No. 71563450



Femoral Trials

Cat. No.	
71562320	PF Trial x-small left
71562321	PF Trial x-small right
71562322	PF Trial small left
71562324	PF Trial medium left
71562326	PF Trial large left
71562323	PF Trial small right
71562325	PF Trial medium right
71562327	PF Trial large right



Quick Release T-Handle

Cat. No. 71110080



Putti Rasp

Cat. No. 210071



Femoral Drill

Cat. No. 71563436



Universal Pin Puller

Cat. No. 71440491



PF Peg Drill

Cat. No. 71563416



Drill Guide Alignment Peg (3)

Cat. No. 71563417



PROFIX[®] Bone Spike Inserter

Cat. No. 71513366



1.75" Bone Spike

Cat. No. 71563415



PROFIX Long Bone Spike

Cat. No. 71513367



Quick Connect Trocar Pin 1/8" x 2.25"

Cat. No. 71563425



Mini Connector

Cat. No. 71631186



Quick Connect 1/8" Drill Bit

Cat. No. 74012905



JOURNEY[◇] PFJ Implant Constructs

Main construct

Femoral	Patella
JOURNEY PFJ Femoral (OXINIUM [®])	GENESIS [◇] II Round Resurfacing Patella GENESIS II Biconvex Patella

JOURNEY PFJ Compatibility

JOURNEY PFJ Femoral (OXINIUM [®])
Patella GENESIS II Round Resurfacing Patella GENESIS II Biconvex Patella

Compatibility Table

JOURNEY [®] PFJ Component	Compatible Component	Size
JOURNEY PFJ Femoral (OXINIUM [®])	GENESIS [®] II Round Resurfacing Patella	26-41 mm
	GENESIS II Biconvex Patella	23-32 mm

References

1. Ackroyd, C., "Development and Early Results of a New Patellofemoral Arthroplasty," Clinical Orthopaedics and Related Research (Supplement), Number 436, pp. 7-13.
2. Stiehl J, Cherveney P. Femoral rotational alignment using the tibial shaft axis in total knee arthroplasty. Ovid: Stiehl: Clin Orthop, Volume (331).October 1996.47-55

Products may not be available in all markets because product availability is subject to the regulatory and/or medical practices in individual markets. Please contact your Smith & Nephew representative or distributor if you have questions about the availability of Smith & Nephew products in your area.

Smith & Nephew, Inc.

1450 Brooks Road
Memphis, TN 38116
USA

www.smith-nephew.com

Telephone: 1-901-396-2121
Information: 1-800-821-5700
Orders/inquiries: 1-800-238-7538

®Trademark of Smith & Nephew.
All Trademarks acknowledged.

©2023 Smith & Nephew, Inc.
All rights reserved.
00579 V2 71282162 REVA 05/23